

Tribological Processes of an Additively Manufactured Small Joint Implant under Simulated Conditions

Ing. Lukáš Odehnal

Supervisor: prof. Ing. Martin Vrbka, Ph.D.

Supervisor specialist: Ing. Matúš Ranuša, Ph.D.

Biotribology Research Group

Institute of Machine and Industrial Design

Faculty of Mechanical Engineering

Brno University of Technology

Brno, 6th May 2026

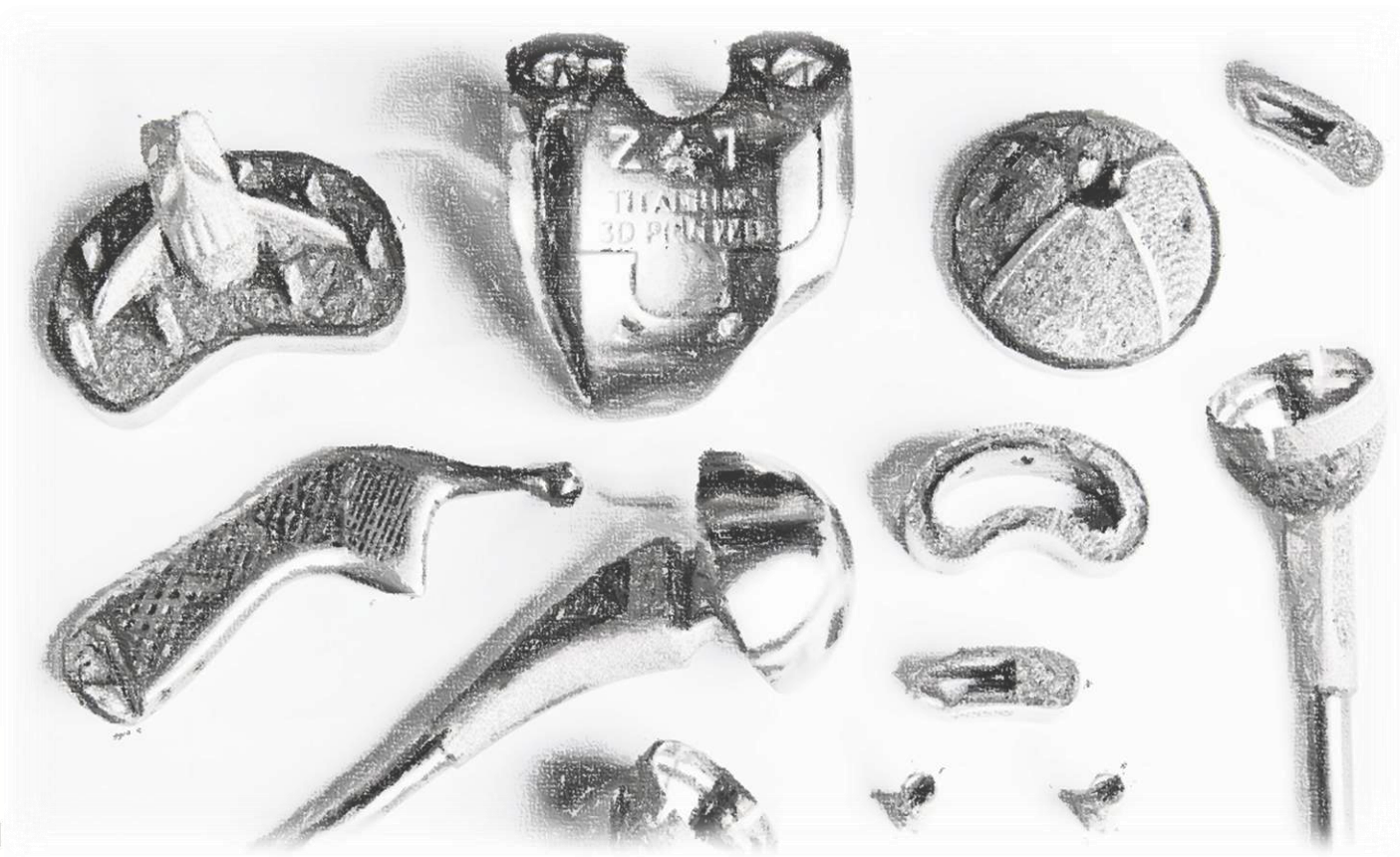

Background and Motivation

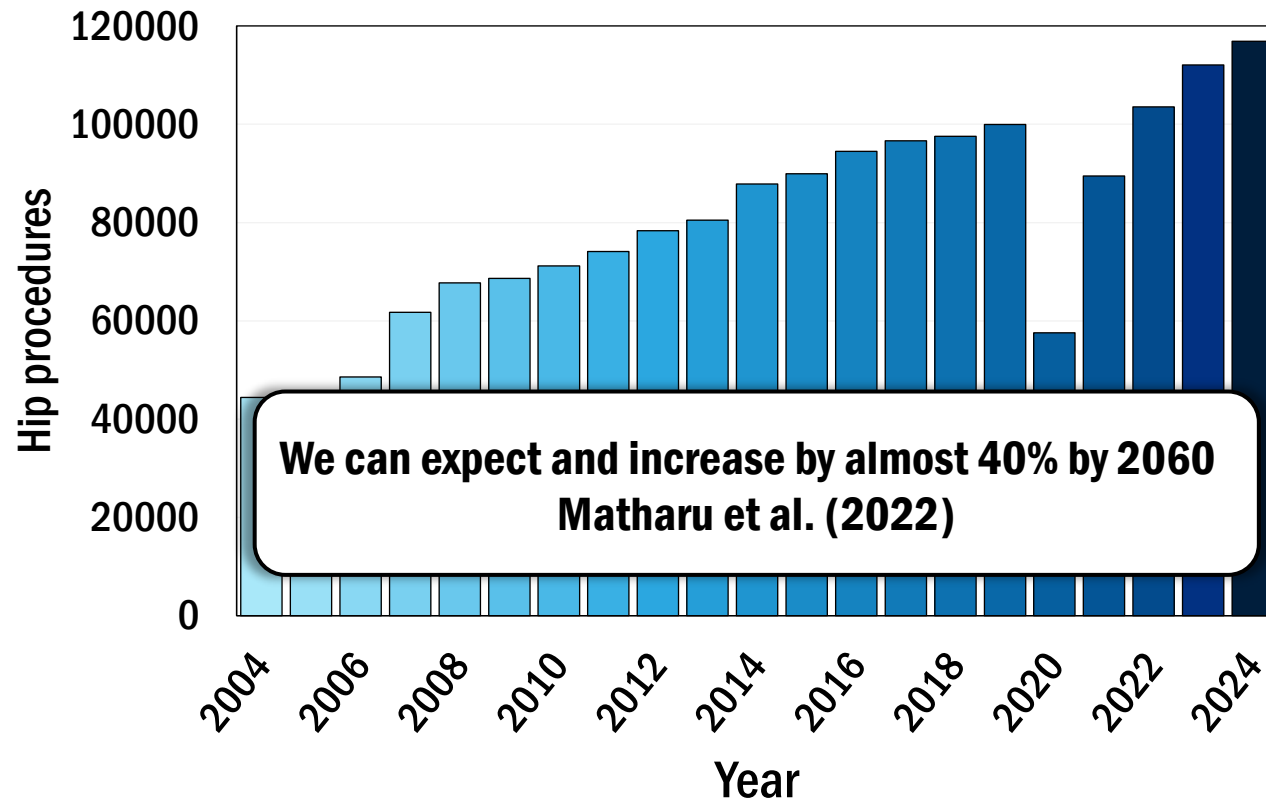

Number of primary operations for the hip joint
(National Joint Registry)

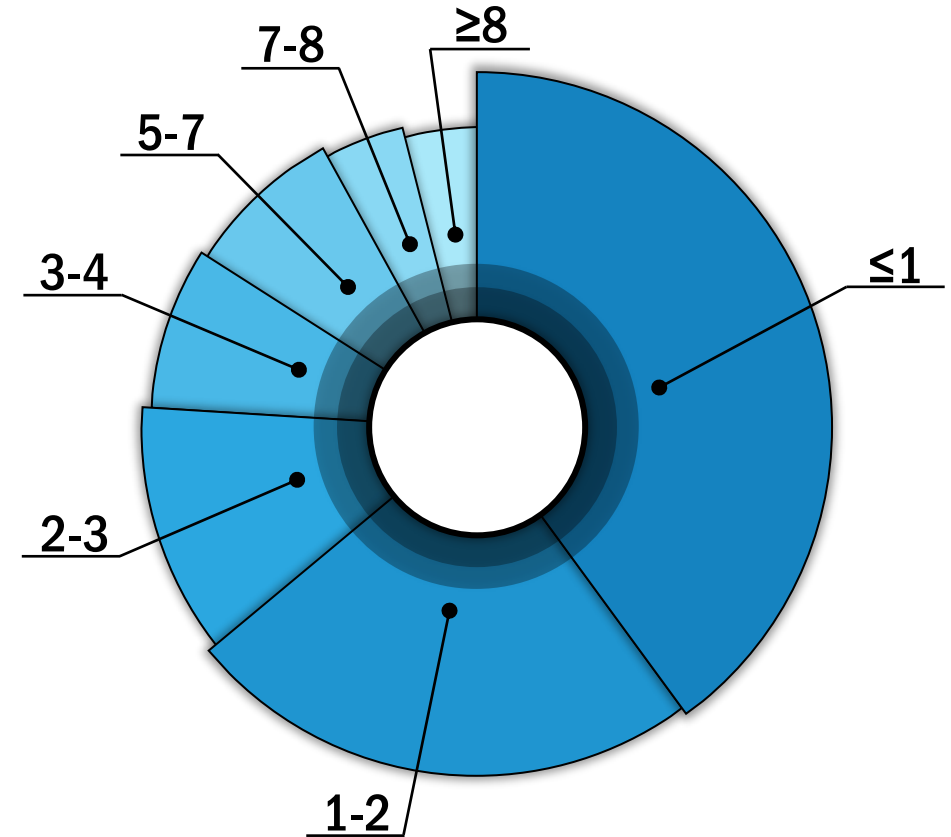

Number of years until revision (1. MTP joint)
(US Food and Drug Administration)

Background and Motivation

We already have promising clinical experience with 3D printed materials.



Is it possible to use 3D printed parts also for frictional surfaces?



Global Objectives

What is our goal?



- **Restore mobility and reduce pain**
- **Improve quality of life**
- **Support independent living and return to work**
- **Lower societal and healthcare costs**

Global Objectives

What is our goal?



- **Restore mobility and reduce pain**
- **Improve quality of life**
- **Support independent living and return to work**
- **Lower societal and healthcare costs**

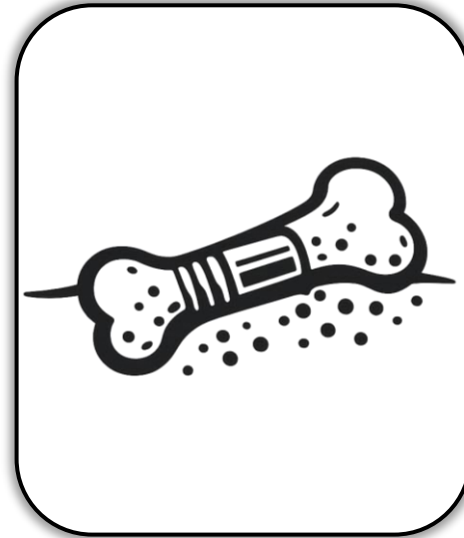
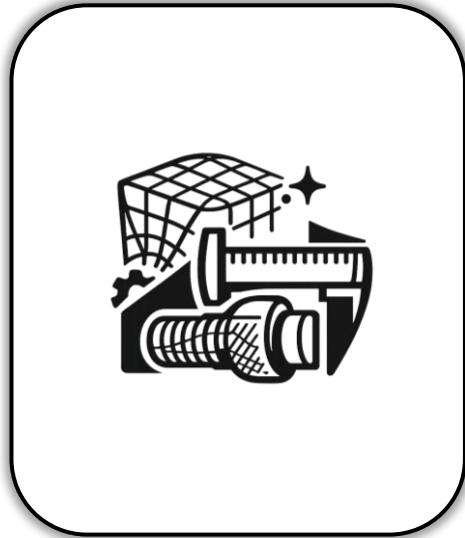

Global Objectives

What is our goal?



- Restore mobility and reduce pain
- Improve quality of life
- Support independent living and return to work
- Lower societal and healthcare costs



Design
Manufacturing

Geometry Optimisation
Coatings & Textures
Type of Manufacturing



Global Objectives

What is our goal?



- Restore mobility and reduce pain
- Improve quality of life
- Support independent living and return to work
- Lower societal and healthcare costs



**Design
Manufacturing**

Geometry Optimisation
Coatings & Textures
Type of Manufacturing



**Physiological
Environment**

Synovial Fluid
Protein Adsorption
Oxidative environment



Global Objectives

What is our goal?



- Restore mobility and reduce pain
- Improve quality of life
- Support independent living and return to work
- Lower societal and healthcare costs



**Design
Manufacturing**

Geometry Optimisation
Coatings & Textures
Type of Manufacturing



**Physiological
Environment**

Synovial Fluid
Protein Adsorption
Oxidative environment



**Biological
Response**

Tissue Integration
Osteolysis
Ion Release



Global Objectives

What is our goal?



- Restore mobility and reduce pain
- Improve quality of life
- Support independent living and return to work
- Lower societal and healthcare costs



Design Manufacturing

Geometry Optimisation
Coatings & Textures
Type of Manufacturing



Physiological Environment

Synovial Fluid
Protein Adsorption
Oxidative environment



Biological Response

Tissue Integration
Osteolysis
Ion Release



Mechanical & Material Factors

Wear & Fatigue
Friction & Lubrication
Surface Integrity

State of the Art

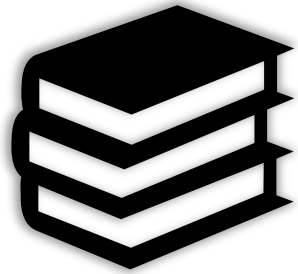

**What do we know
from the literature?**

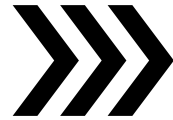

Materials



Additive Manufacturing

Surface Engineering

Tribological Behaviour

State of the Art

Materials

- Ti6Al4V is widely used due to good mechanical properties, biocompatibility, and relatively low elastic modulus.
- Limitations include stress shielding, and ion toxicity.

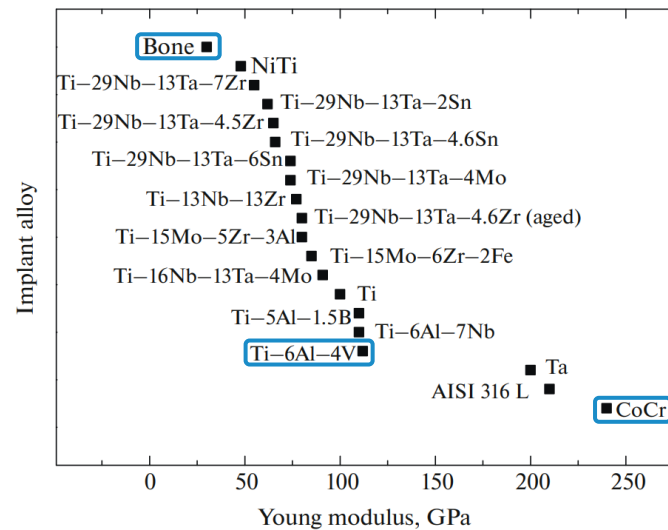

Straumal et al. (2020)

State of the Art

Materials

- Ti6Al4V is widely used due to good mechanical properties, biocompatibility, and relatively low elastic modulus.
- Limitations include stress shielding, and ion toxicity.

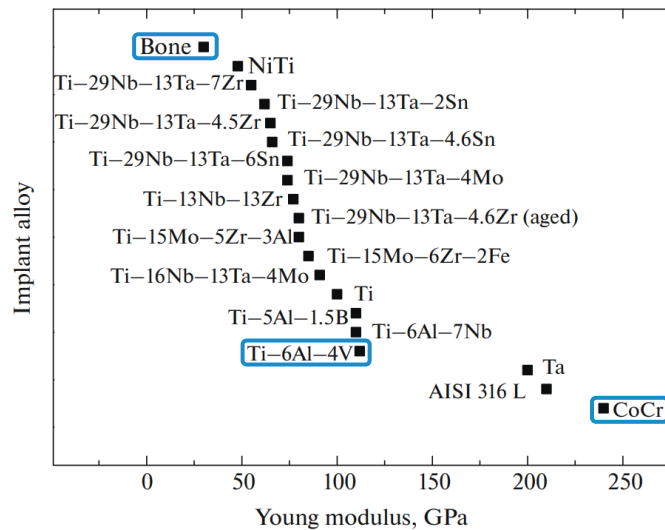

Straumal et al. (2020)

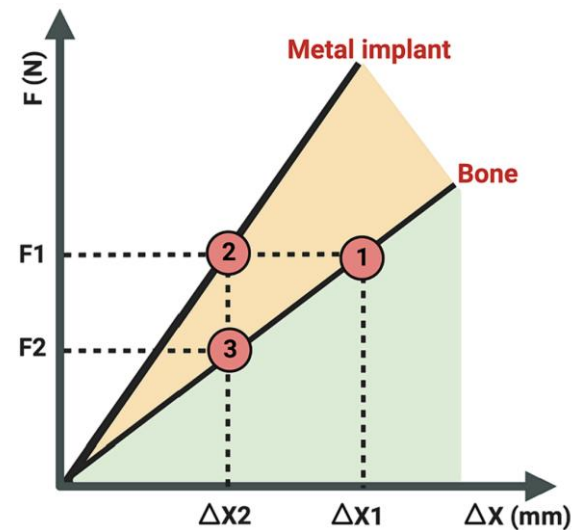

Abd-Elaziem et al. (2024)

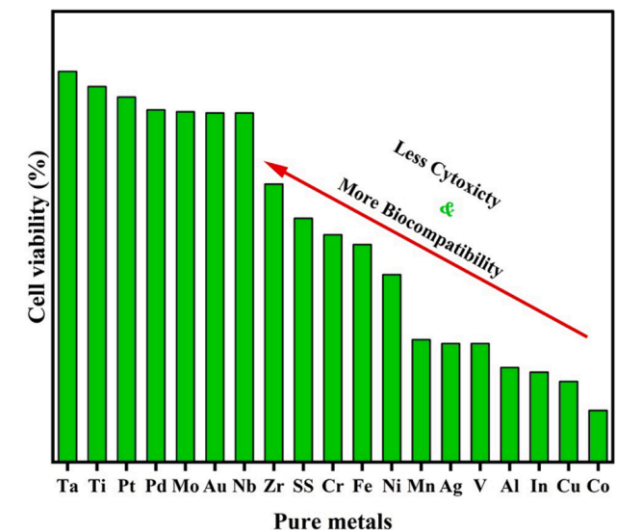

State of the Art

Additive Manufacturing

- Complex geometries, lattice structures, patient-specific implant designs.
- AM Ti6Al4V typically exhibits a martensitic α microstructure.
- Microstructural features influence mechanical properties and tribological response.



State of the Art

Additive Manufacturing

- Complex geometries, lattice structures, patient-specific implant designs.
- AM Ti6Al4V typically exhibits a martensitic α microstructure.
- Microstructural features influence mechanical properties and tribological response.

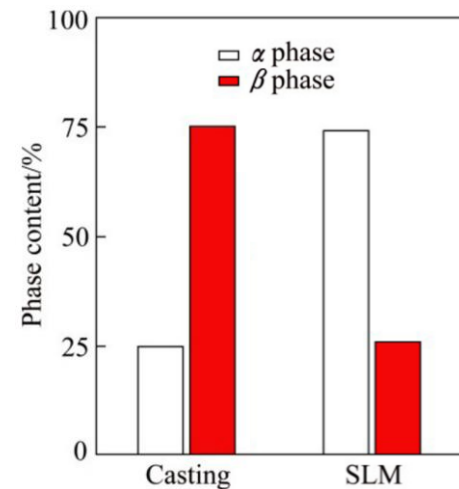

Bartolomeu et al. (2017)

State of the Art

Additive Manufacturing

- Complex geometries, lattice structures, patient-specific implant designs.
- AM Ti6Al4V typically exhibits a martensitic α microstructure.
- Microstructural features influence mechanical properties and tribological response.

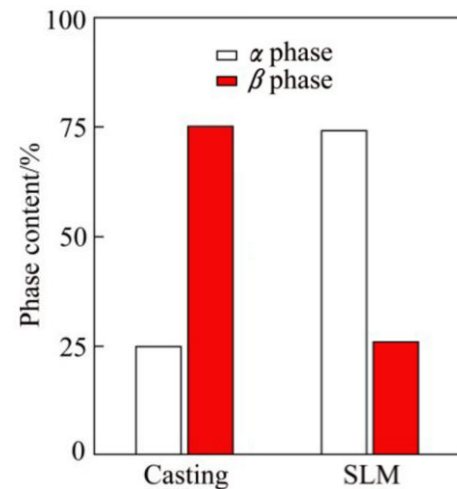

Bartolomeu et al. (2017)

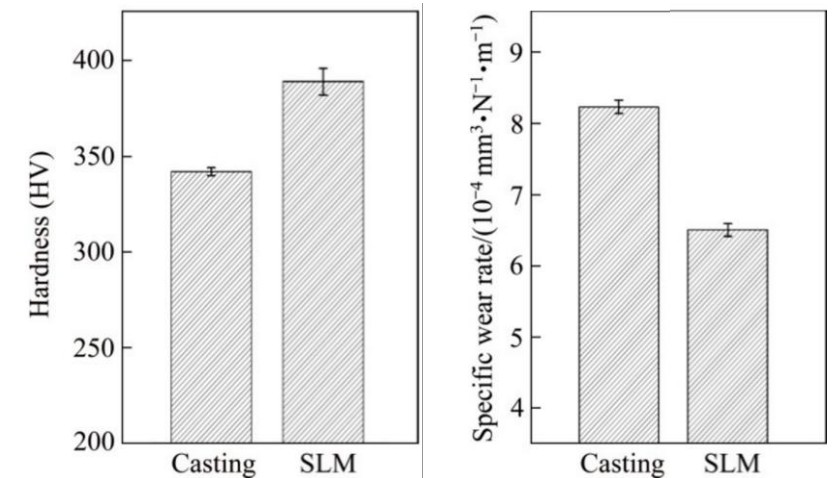

Bartolomeu et al. (2017)

State of the Art

Surface Engineering

- Surface modification is widely used to improve tribological behaviour.
- Surface texturing can improve lubrication and reduce pressures.
- Laser polishing reduces roughness and improves both wear and corrosion resistance.

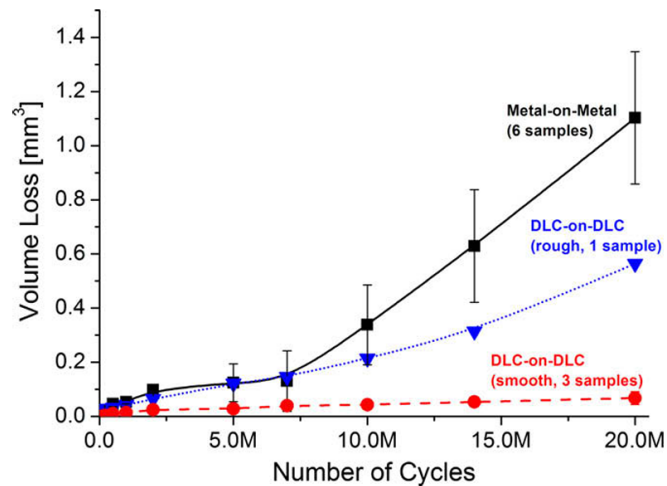

Thorwarth et al. (2010)

State of the Art

Surface Engineering

- Surface modification is widely used to improve tribological behaviour.
- Surface texturing can improve lubrication and reduce pressures.
- Laser polishing reduces roughness and improves both wear and corrosion resistance.

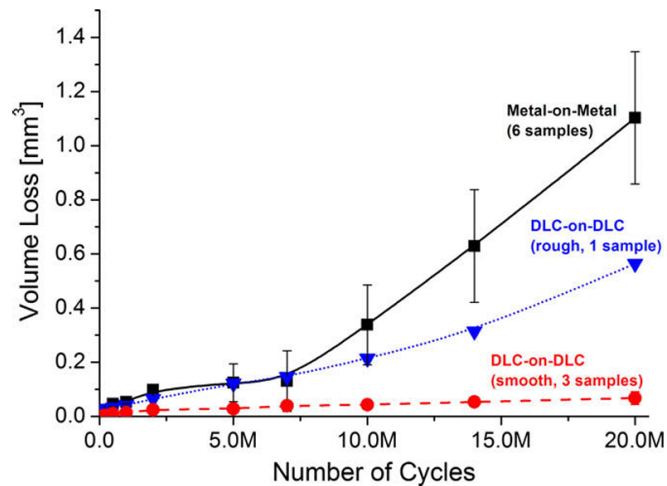

Thorwarth et al. (2010)

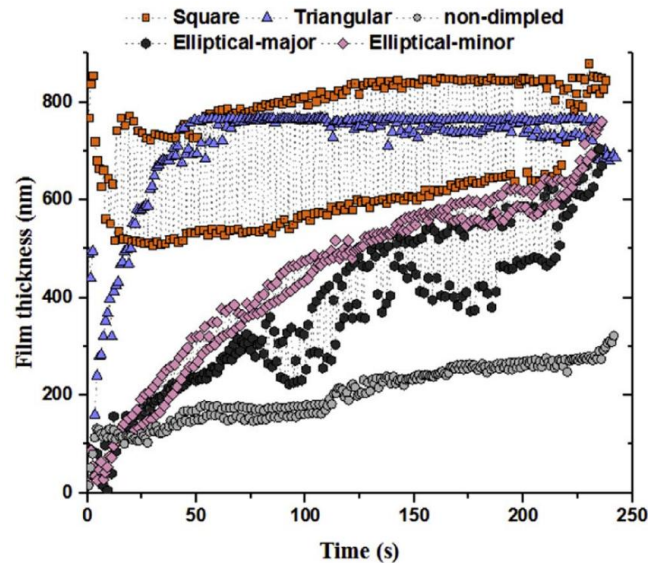

Choudhury et al. (2018)

State of the Art

Surface Engineering

- Surface modification is widely used to improve tribological behaviour.
- Surface texturing can improve lubrication and reduce pressures.
- Laser polishing reduces roughness and improves both wear and corrosion resistance.

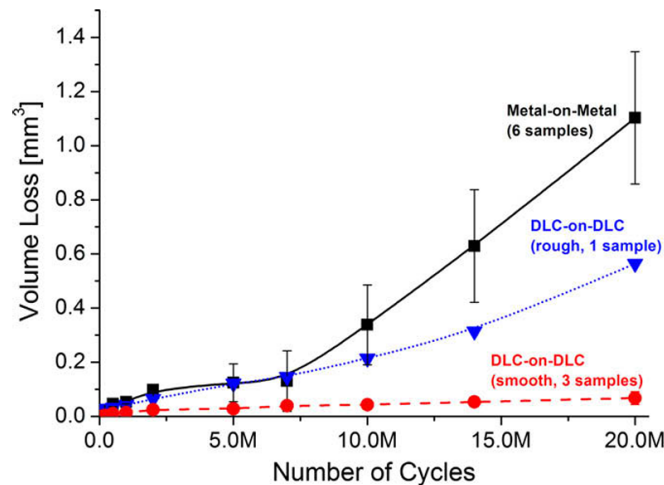

Thorwarth et al. (2010)

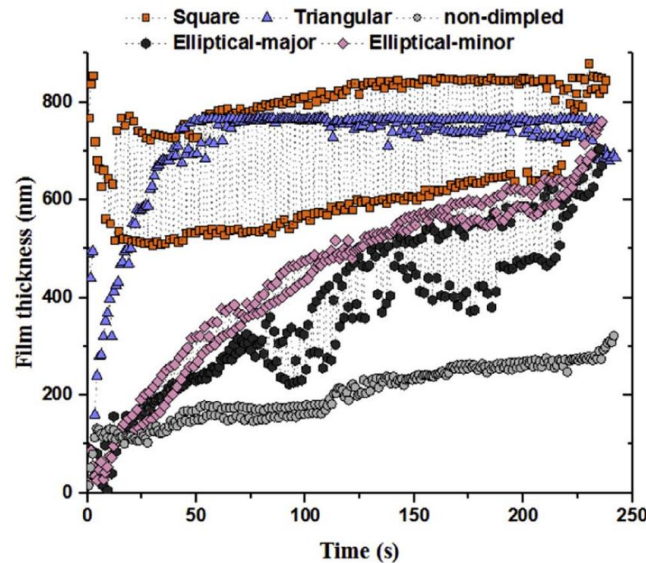

Choudhury et al. (2018)

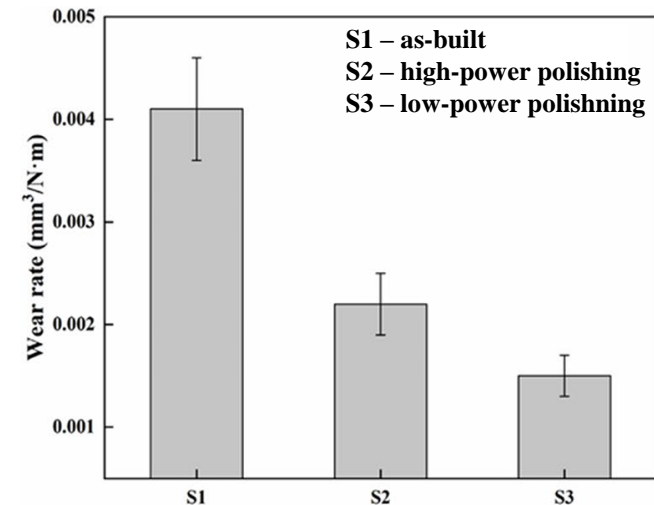

Jiejingy et al. (2023)

State of the Art

Tribological Behaviour

- Artificial joint lubrication is specific due to protein-rich synovial fluid composition.
- The Protein Aggregation Lubrication (PAL) explains formation of viscous protein films.
- Synovial fluid constituents contribute to multilayer adsorption.

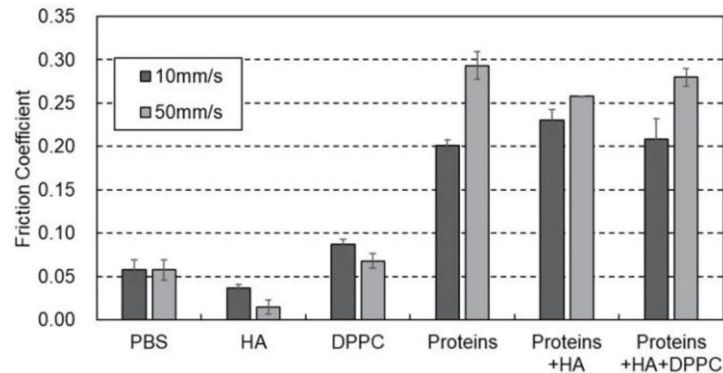

Shinmori et al. (2020)

State of the Art

Tribological Behaviour

- Artificial joint lubrication is specific due to protein-rich synovial fluid composition.
- The Protein Aggregation Lubrication (PAL) explains formation of viscous protein films.
- Synovial fluid constituents contribute to multilayer adsorption.

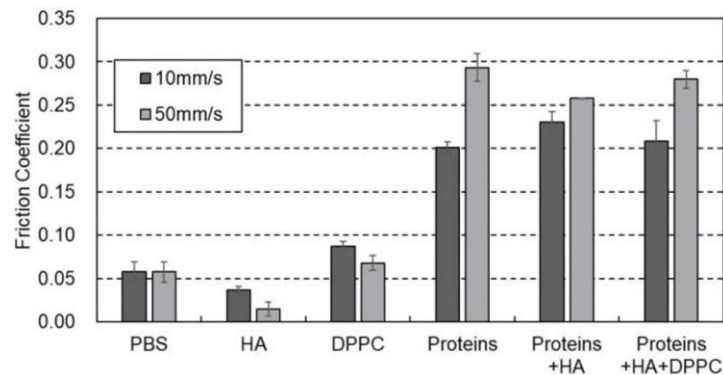

Shinmori et al. (2020)

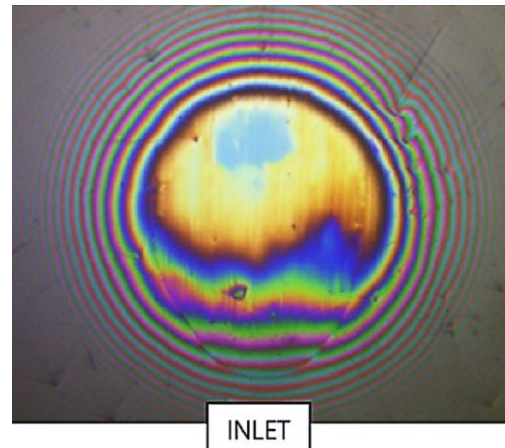

Myant et al. (2012)

State of the Art

Tribological Behaviour

- Artificial joint lubrication is specific due to protein-rich synovial fluid composition.
- The Protein Aggregation Lubrication (PAL) explains formation of viscous protein films.
- Synovial fluid constituents contribute to multilayer adsorption.

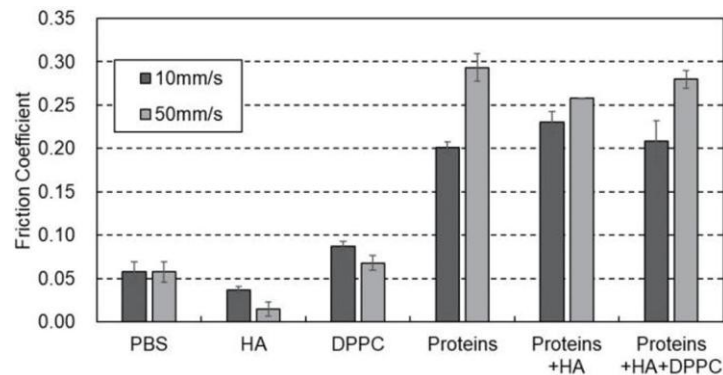

Shinmori et al. (2020)

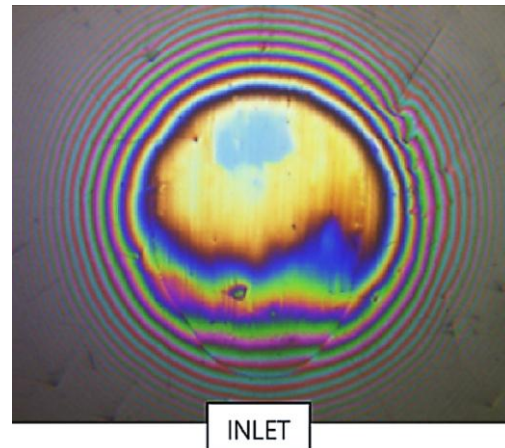

Myant et al. (2012)

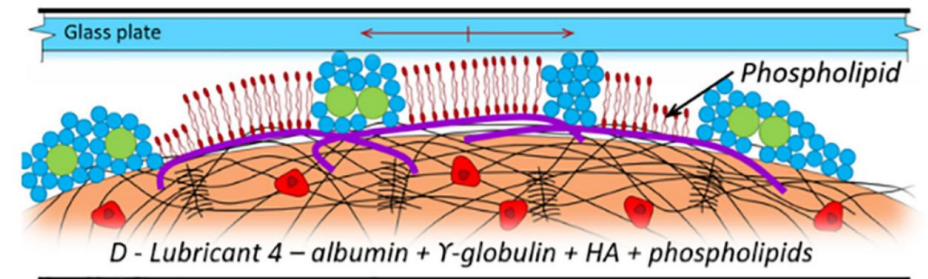

Čípek et al. (2022)

State of the Art

Identified knowledge gaps

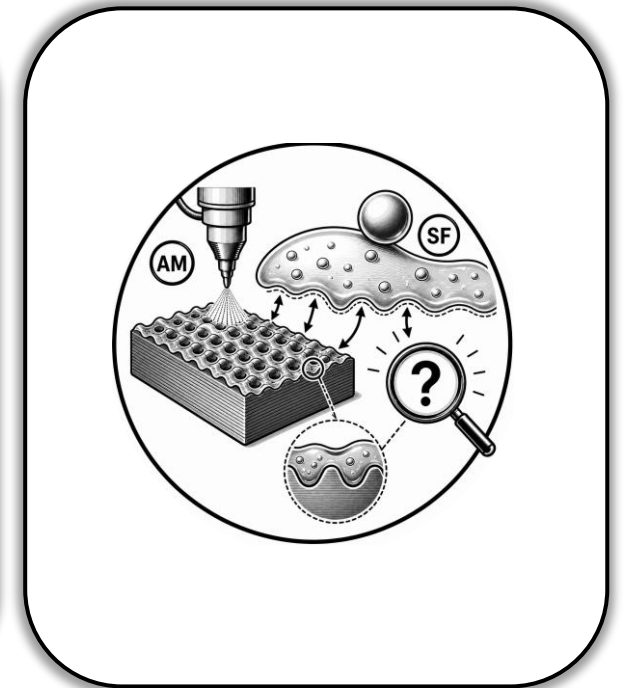
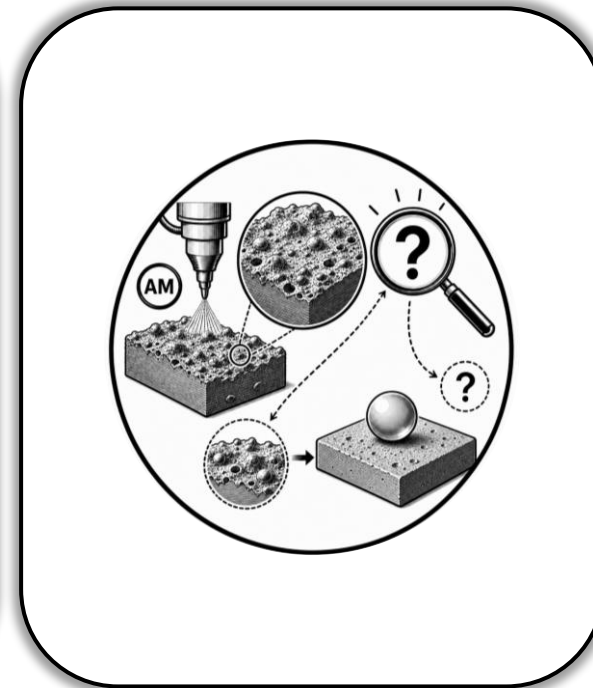
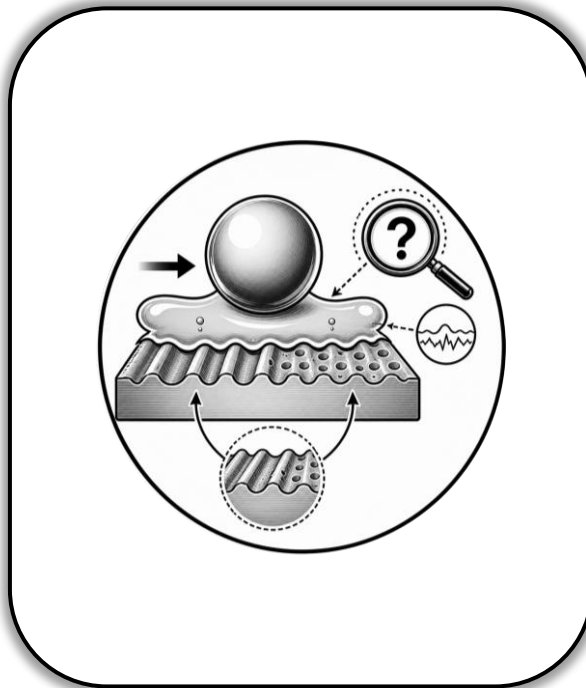
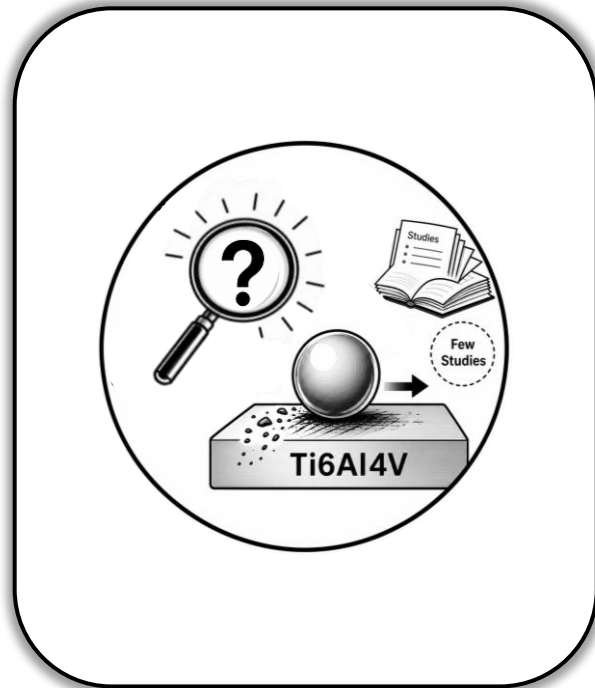

State of the Art

Identified knowledge gaps



The tribological behaviour of Ti6Al4V remains insufficiently characterised.

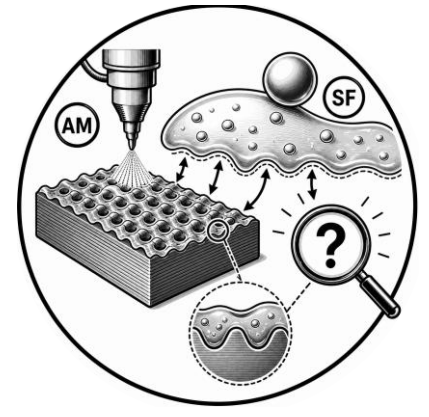
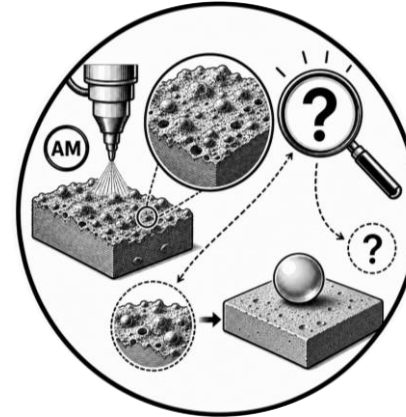
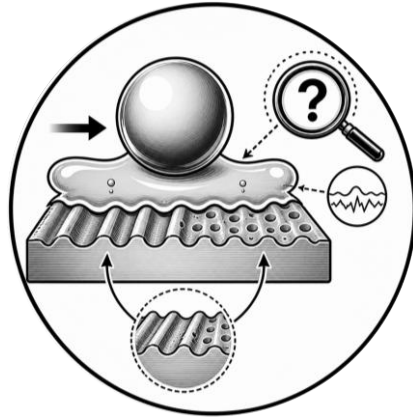

State of the Art

Identified knowledge gaps



The tribological behaviour of Ti6Al4V remains insufficiently characterised.

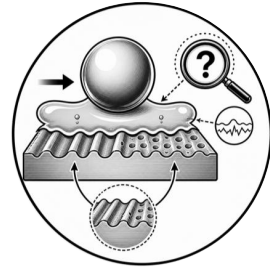

The role of surface texture in lubricant film stability is not yet fully understood.

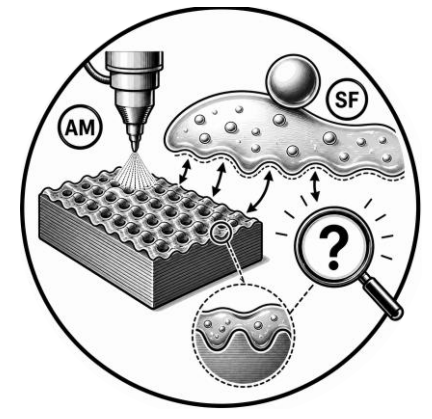
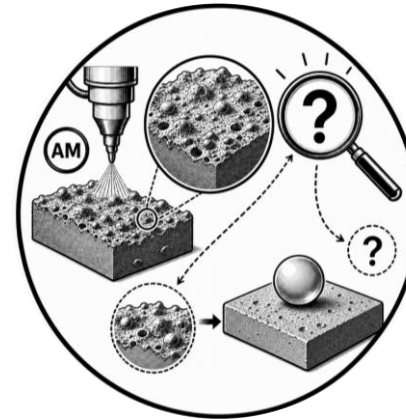

State of the Art

Identified knowledge gaps



The tribological behaviour of Ti6Al4V remains insufficiently characterised.

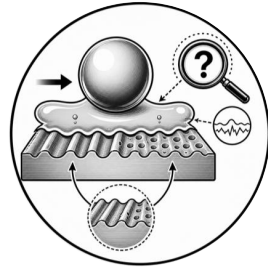

The role of surface texture in lubricant film stability is not yet fully understood.

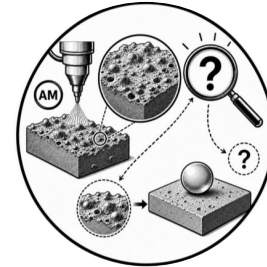

The potential of as-built AM surface features for functional texturing remains unclear.

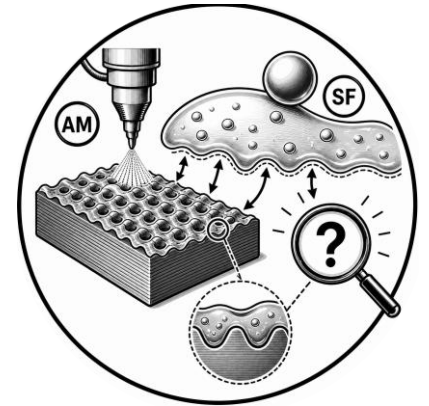

State of the Art

Identified knowledge gaps



The tribological behaviour of Ti6Al4V remains insufficiently characterised.

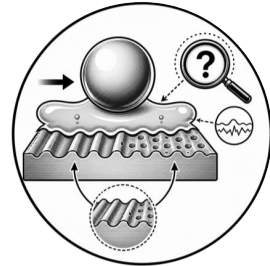

The role of surface texture in lubricant film stability is not yet fully understood.

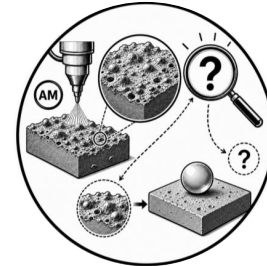

The potential of as-built AM surface features for functional texturing remains unclear.

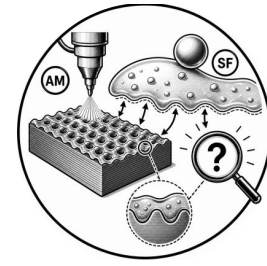

Interactions between process-controlled AM surface structures and SF are unknown.

Aim of the Thesis

Describe the tribological behaviour of additively manufactured Ti6Al4V alloy with enhanced surface for use in joint implants, with focus on comparison to the conventionally used CoCr30Mo6 alloy.

Friction

**Lubrication film
thickness**

**M-SF constituents
behaviour**

Wear

Materials and Methods

Friction

- Tribometer with pin-on-plate configuration
- Observation of the contact area

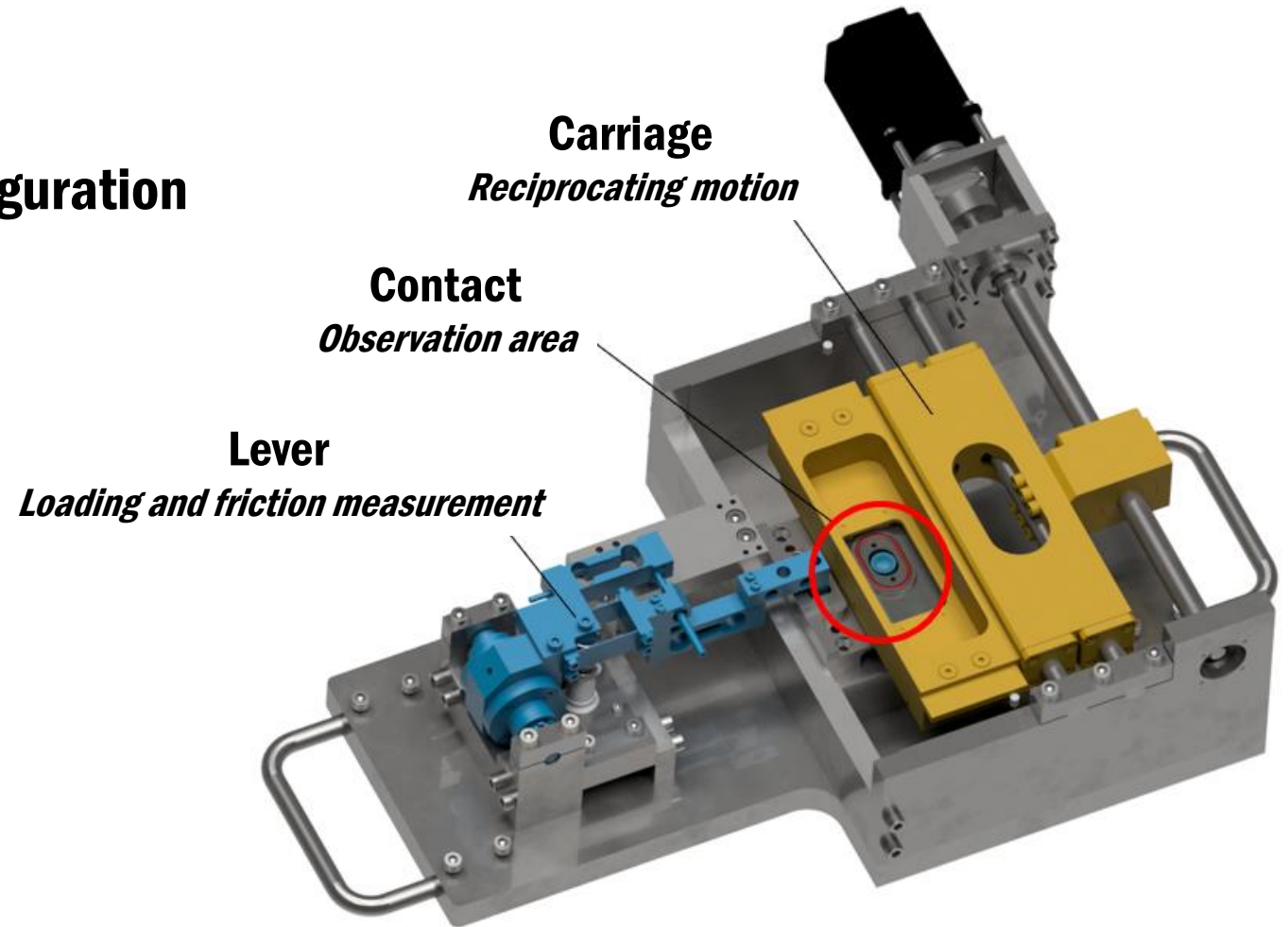

Materials and Methods

Lubrication film thickness

- Colourimetric interferometry
- Measurement of lubrication film thickness
- Comparison of exact number

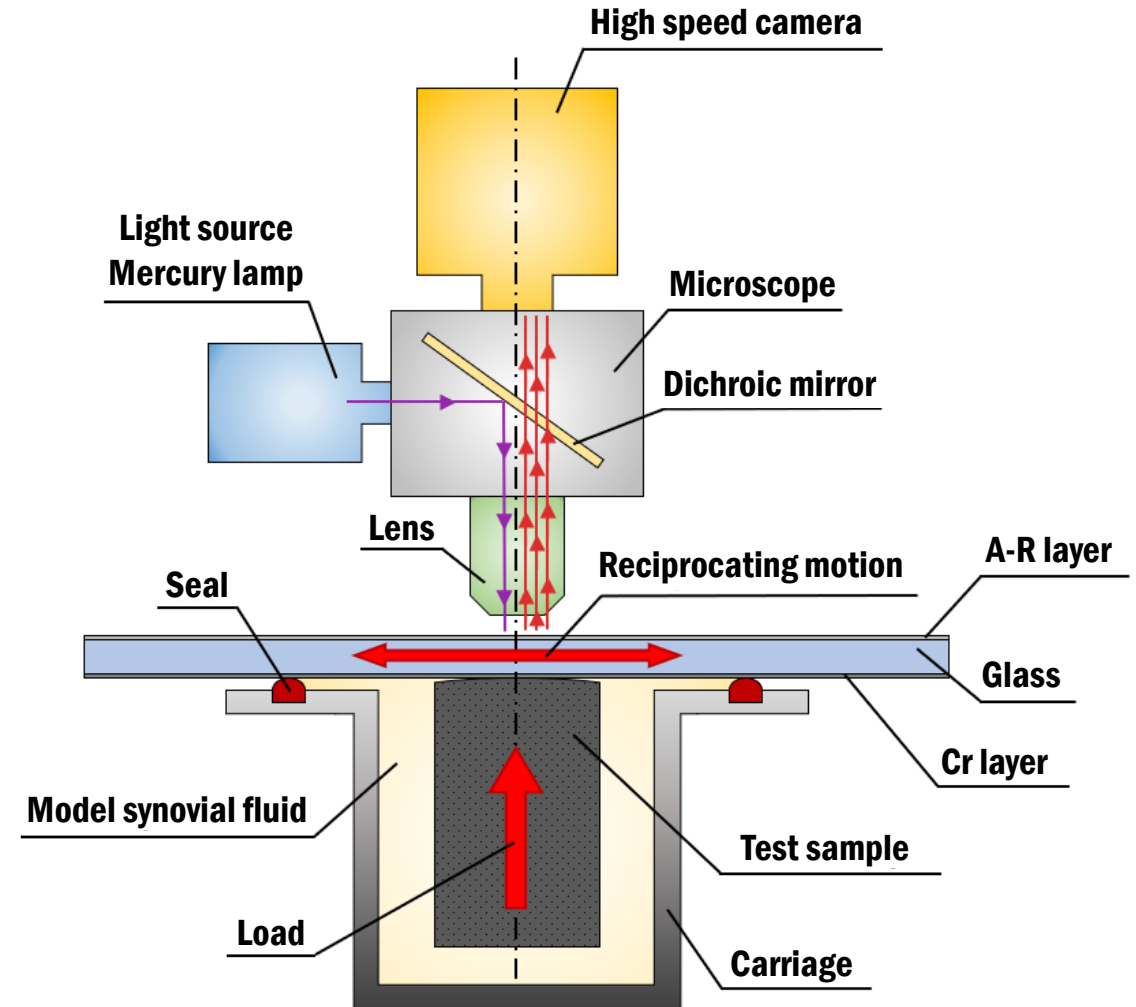

Materials and Methods

M-SF constituents behaviour

- Fluorescence microscopy
- Observation of each M-SF constituents
- Comparative method

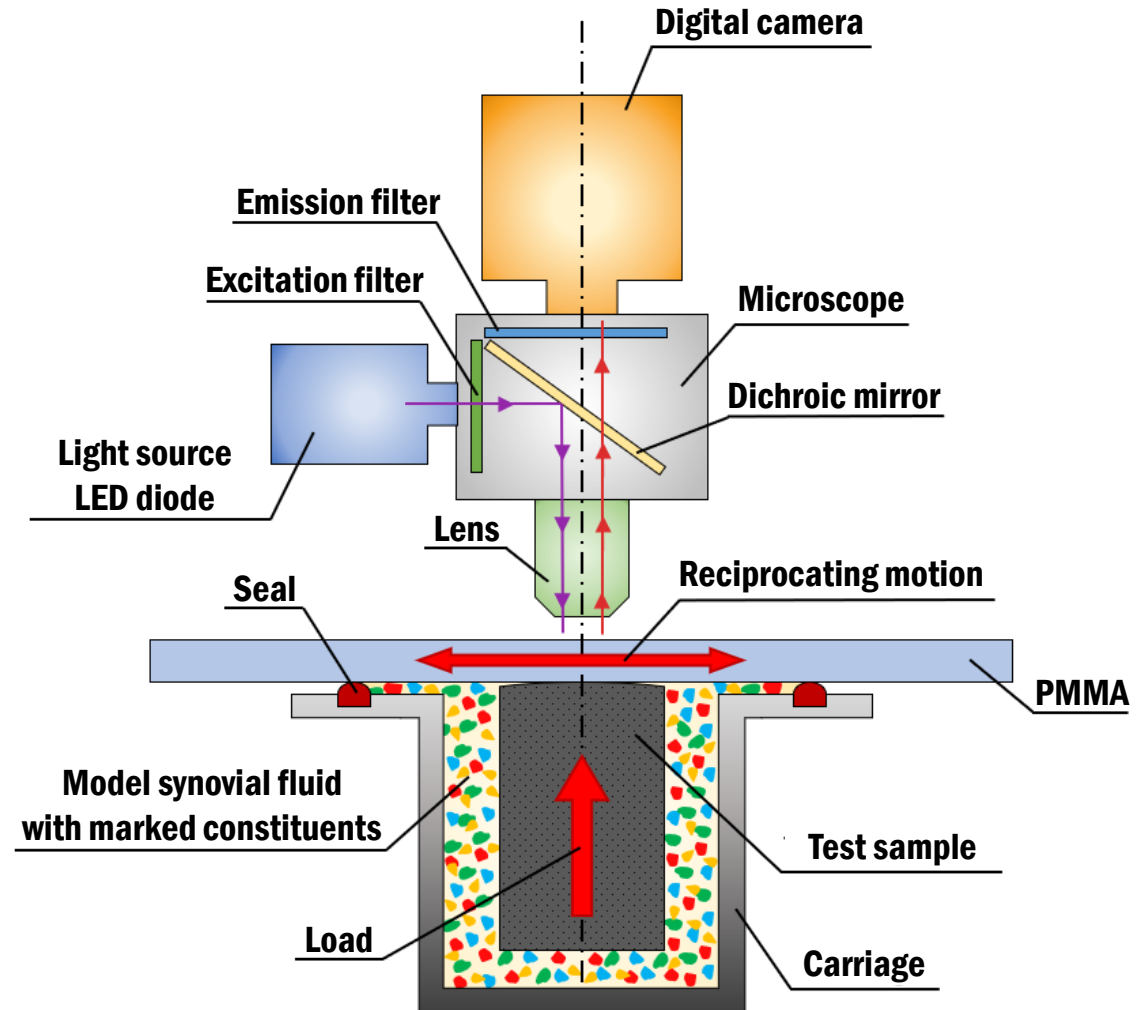

Materials and Methods

Long-term wear

- Two simultaneous stations
- Up to 300 000 cycles
- Peristaltic pumps

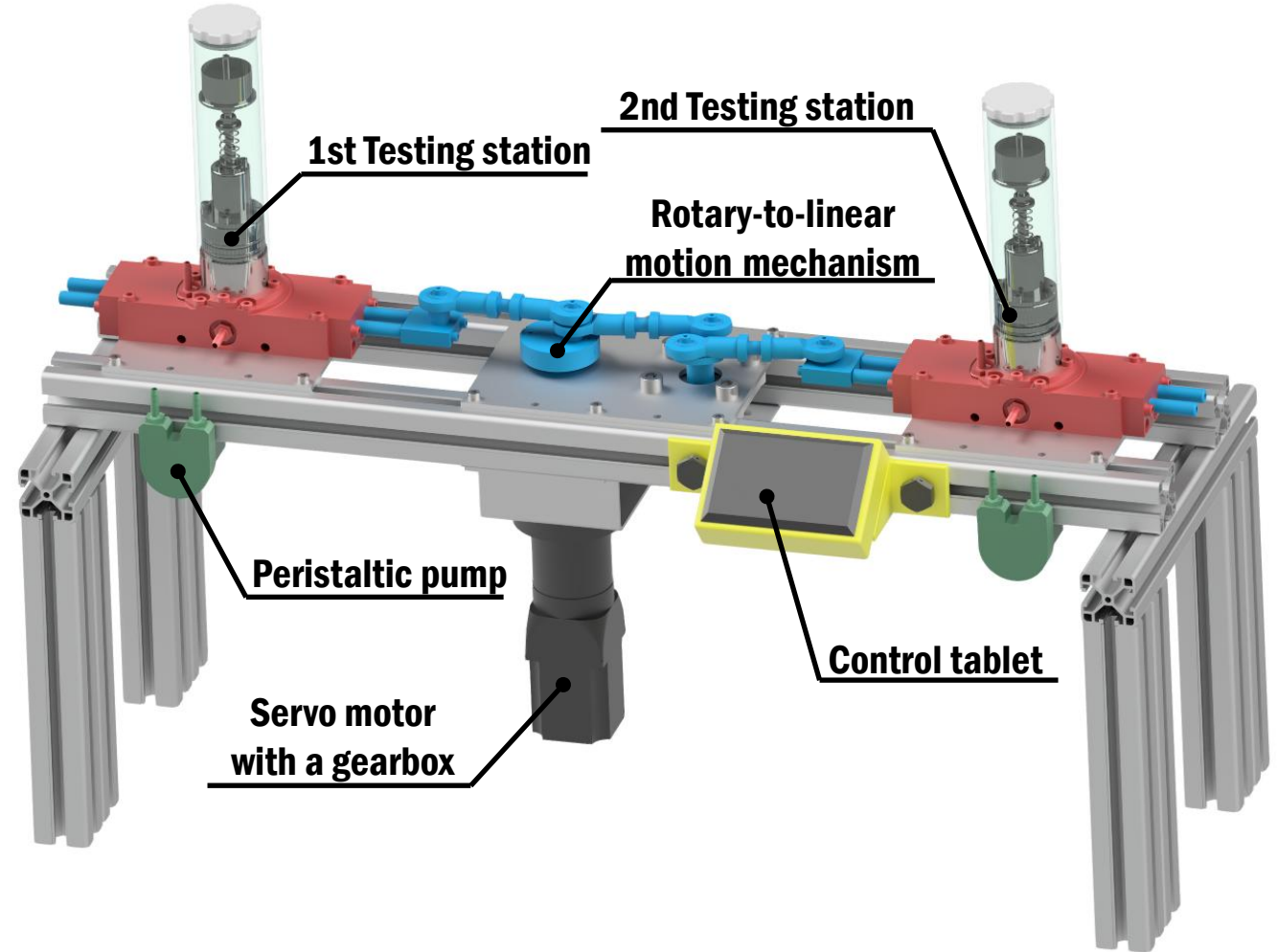

Materials and Methods

Design of experiments

- **Metal-on-Polymer (the most typical joint implant)**
- Model synovial fluid as a lubricant
- Kinematics and loading derived from real joint

- CM CoCr30Mo6
- CM Ti6Al4V
- CM Ti6Al4V + laser textures

- AM Ti6Al4V - as-built
- AM Ti6Al4V - grid structure
- AM Ti6Al4V - line structure

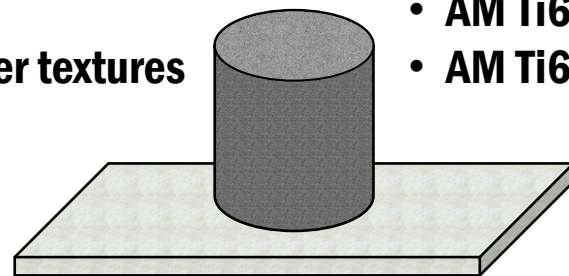

UHMWPE / PMMA / Glass

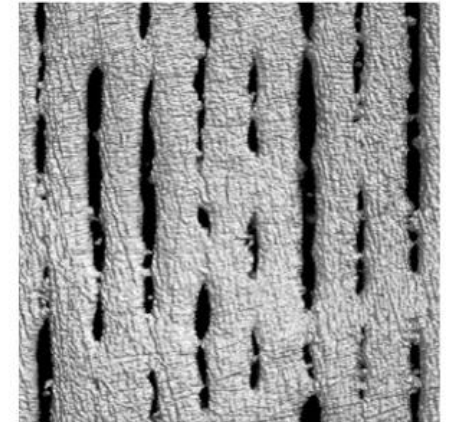
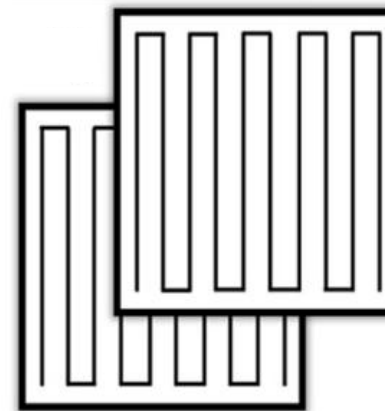
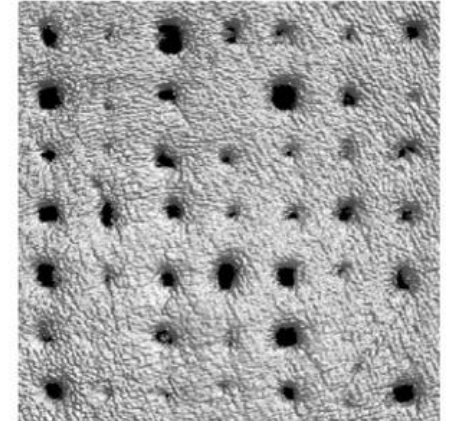
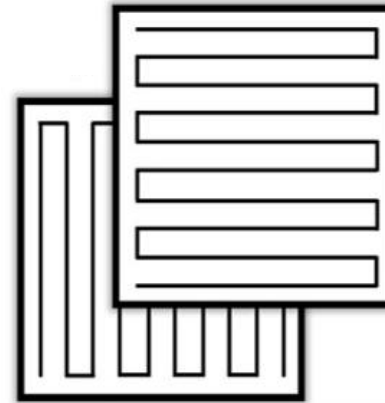

Materials and Methods

Design of experiments

- **Metal-on-Polymer (the most typical joint implant)**
- **Model synovial fluid as a lubricant**
- **Kinematics and loading derived from real joint**



Diluted in PBS:

- **albumin (26.3 mg/ml)**
- **γ -globulin (8.2 mg/ml)**
- **hyaluronic acid (0.82 mg/ml)**
- **phospholipids (0.35 mg/ml)**

rhodamine-B-isothiocyanate - albumin

fluorescein-5-isothiocyanate - γ -globulin/HA

1% solution of L-Glutamine-Penicilin-Streptomycin

Materials and Methods

Design of experiments

- **Metal-on-Polymer (the most typical joint implant)**
- **Model synovial fluid as a lubricant**
- **Kinematics and loading derived from real joint**

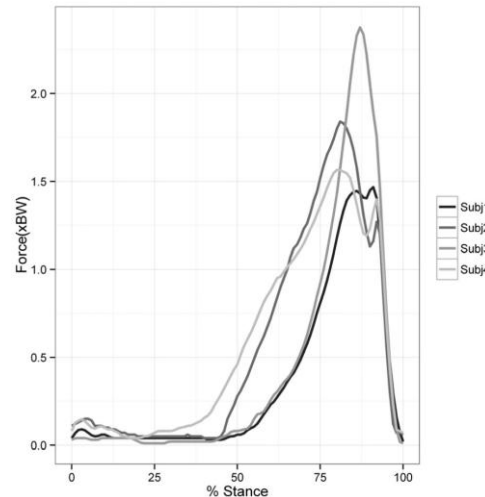
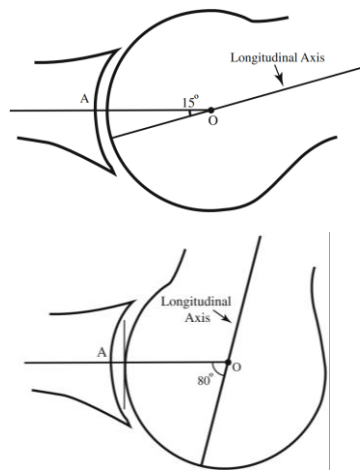

Diluted in PBS:

- **albumin (26.3 mg/ml)**
- **γ -globulin (8.2 mg/ml)**
- **hyaluronic acid (0.82 mg/ml)**
- **phospholipids (0.35 mg/ml)**

rhodamine-B-isothiocyanate – albumin

fluorescein-5-isothiocyanate – γ -globulin/HA

1% solution of L-Glutamine-Penicillin-Streptomycin

Typical experimental conditions:

- **Stroke: 20 mm**
- **Load: 0.5–2 N**
- **Relative speed: 20–40 mm/s**
- **Pin radius: 100 mm**

Results

PHASE 1

**CM CoCr30Mo6
and CM Ti6Al4V**

PHASE 2

**The effect of
lasered textures**

PHASE 3

**AM and controlled
surface structures**

PHASE 4

**Long-term wear
performance**

Phase 1

Conventionally manufactured Ti6Al4V and CoCr30Mo6

Scientific question

How do conventionally manufactured CoCr30Mo6 and Ti6Al4V differ in tribological behaviour under simulated small joint implant conditions?

Hypothesis

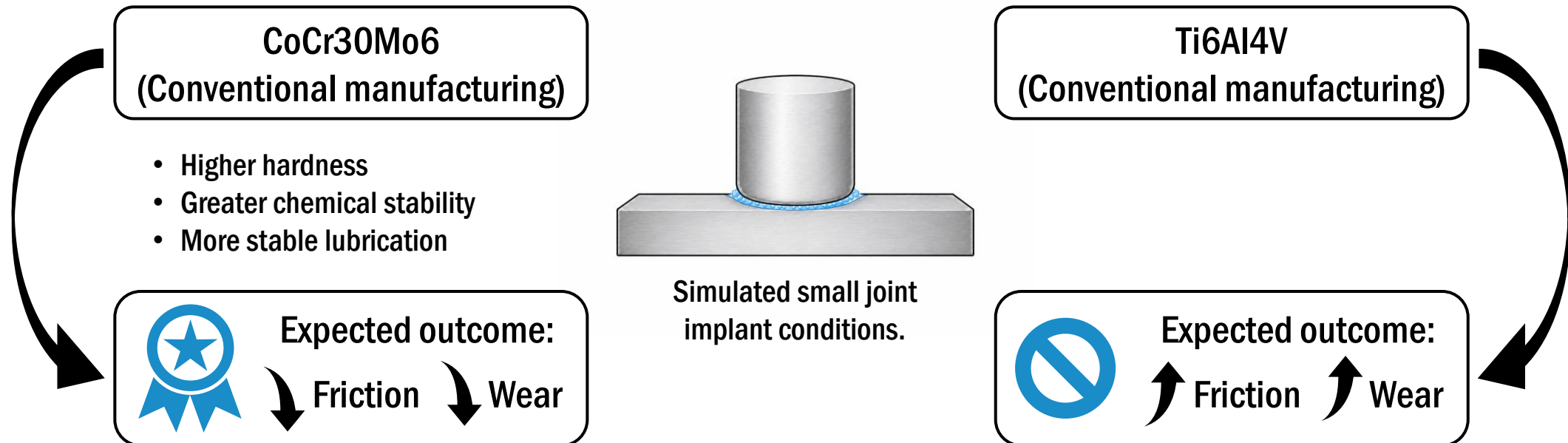

Phase 1

Conventionally manufactured Ti6Al4V and CoCr30Mo6

- Ti6Al4V was not able to form and maintain a sufficiently thick lubrication film.
- The typical inlet zone for PAL was observed only for CoCr30Mo6 sample and only for limited time.
- Based on the friction, there were no significant differences, as both materials stabilised at ~ 0.4 .
- Ti6Al4V exhibited more pronounced wear scars, accompanied by localised deep grooves.

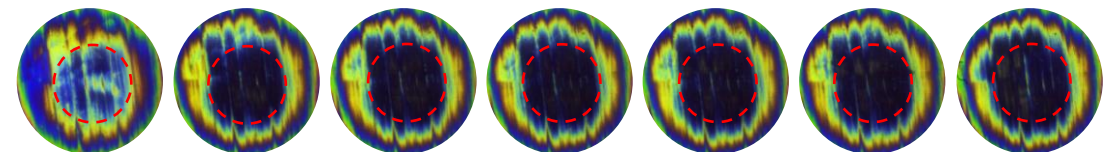
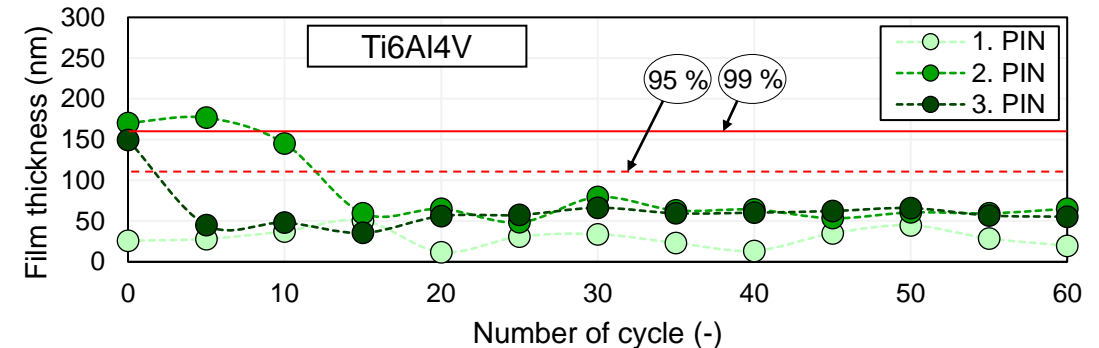
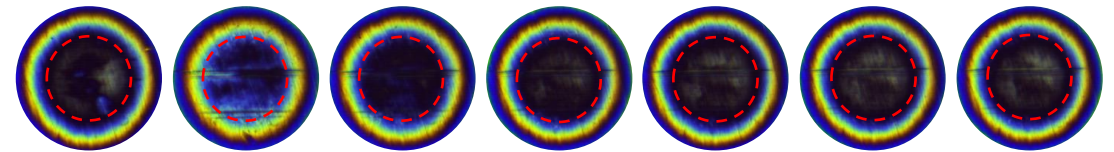
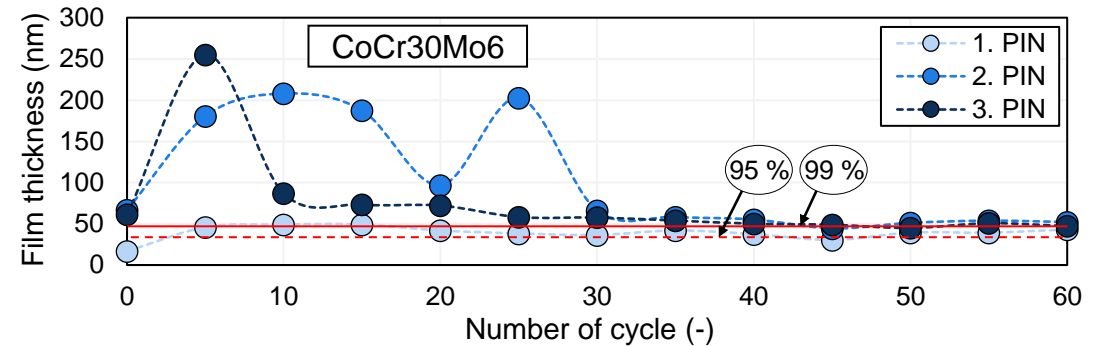

Phase 1

Conventionally manufactured Ti6Al4V and CoCr30Mo6

- Ti6Al4V was not able to form and maintain a sufficiently thick lubrication film.
- The typical inlet zone for PAL was observed only for CoCr30Mo6 sample and only for limited time.
- Based on the friction, there were no significant differences, as both materials stabilised at ~ 0.4 .
- Ti6Al4V exhibited more pronounced wear scars, accompanied by localised deep grooves.

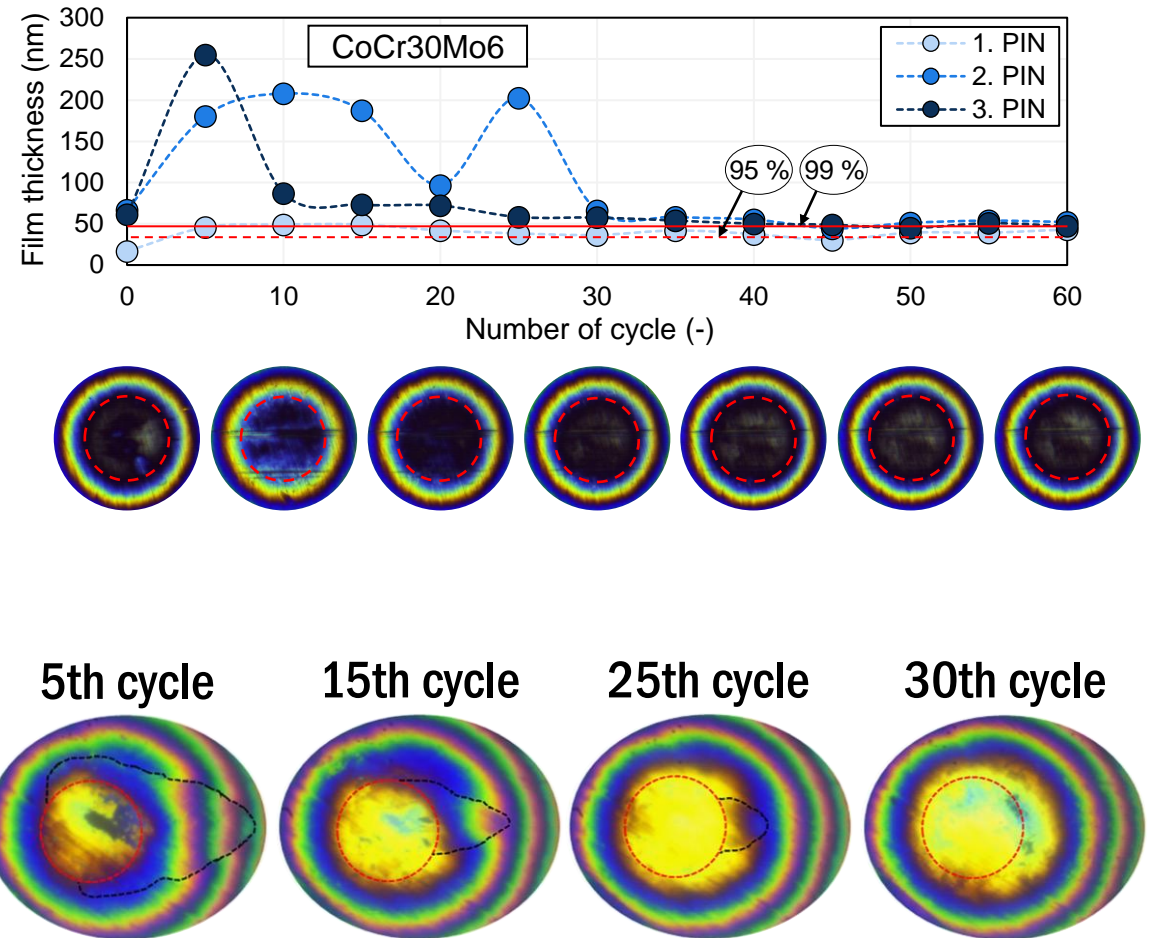

Phase 1

Conventionally manufactured Ti6Al4V and CoCr30Mo6

- Ti6Al4V was not able to form and maintain a sufficiently thick lubrication film.
- The typical inlet zone for PAL was observed only for CoCr30Mo6 sample and only for limited time.
- Based on the friction, there were no significant differences, as both materials stabilised at ~ 0.4 .
- Ti6Al4V exhibited more pronounced wear scars, accompanied by localised deep grooves.

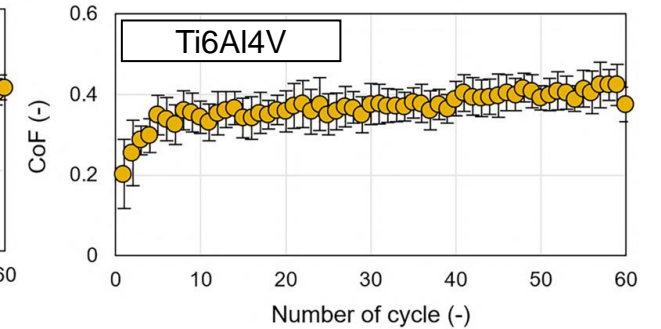
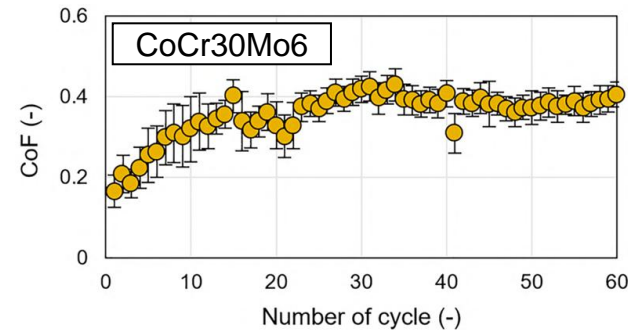

Phase 1

Conventionally manufactured Ti6Al4V and CoCr30Mo6

- Ti6Al4V was not able to form and maintain a sufficiently thick lubrication film.
- The typical inlet zone for PAL was observed only for CoCr30Mo6 sample and only for limited time.
- Based on the friction, there were no significant differences, as both materials stabilised at ~ 0.4 .
- Ti6Al4V exhibited more pronounced wear scars, accompanied by localised deep grooves.

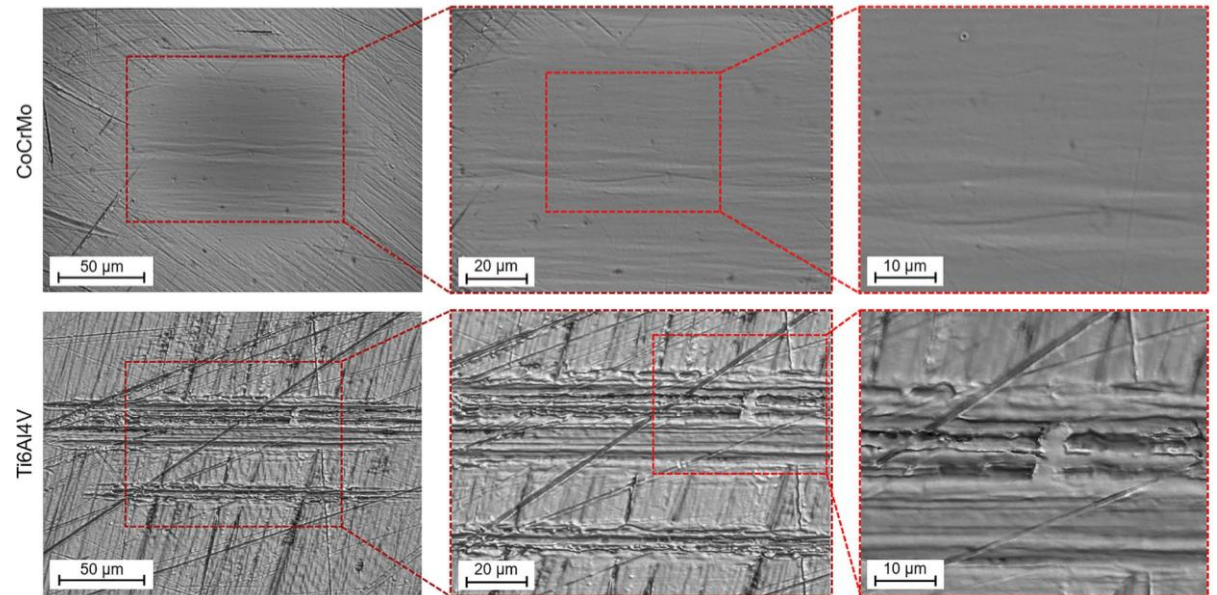
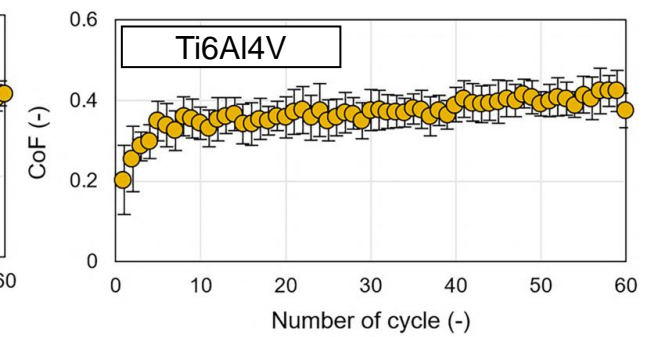
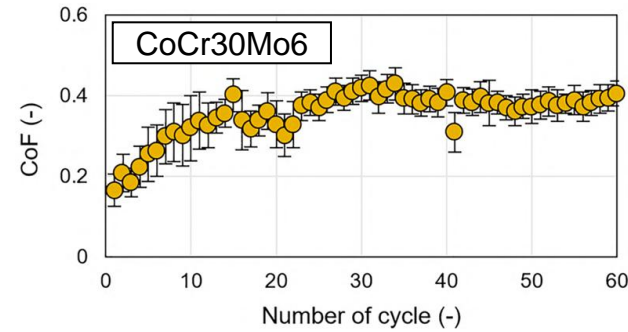

Phase 1

Conventionally manufactured Ti6Al4V and CoCr30Mo6

- Ti6Al4V was not able to form and maintain a sufficiently thick lubrication film.
- The typical inlet zone for PAL was observed only for CoCr30Mo6 sample and only for limited time.
- Based on the friction, there were no significant differences, as both materials stabilised at ~ 0.4 .
- Ti6Al4V exhibited more pronounced wear scars, accompanied by localised deep grooves.

**The hypothesis was
verified.**



Odehnal L, Ranuša M, Vrbka M, Křupka I, Hartl M.
Tribological Behaviour of Ti6Al4V Alloy:
An Application in Small Joint Implants.

Tribol Lett 2023;71:125.

Phase 2

The effect of lasered textures

Research objective

To verify wheter laser texturing can enhance tribological properties of conventionally manufactured Ti6Al4V.



Phase 2

The effect of lasered textures

- Textured surface by laser itself did not improve the overall behaviour due to surface imperfections.
- The electrochemical polishing improved lubrication film in terms of its stability and thickness.
- Coefficient of friction increased for all tested configurations of textures depth.

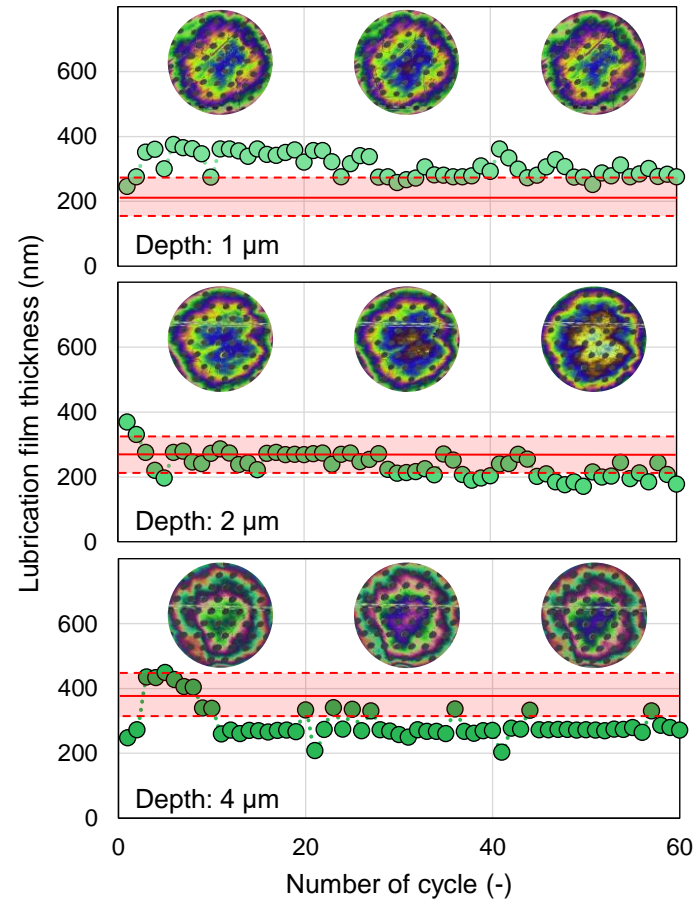

Phase 2

The effect of lasered textures

- Textured surface by laser itself did not improve the overall behaviour due to surface imperfections.
- The electrochemical polishing improved lubrication film in terms of its stability and thickness.
- Coefficient of friction increased for all tested configurations of textures depth.

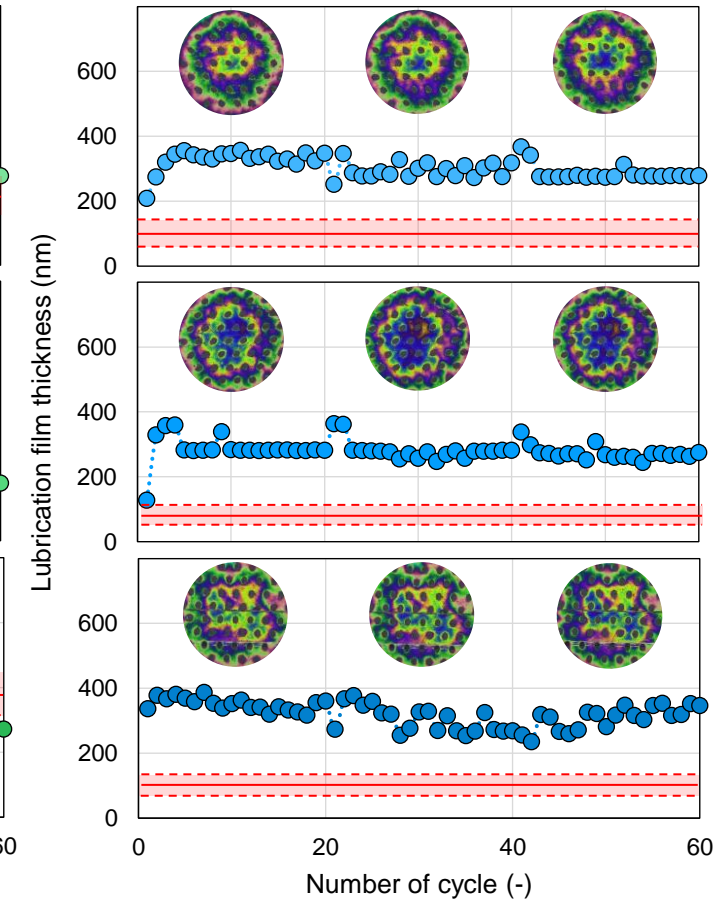
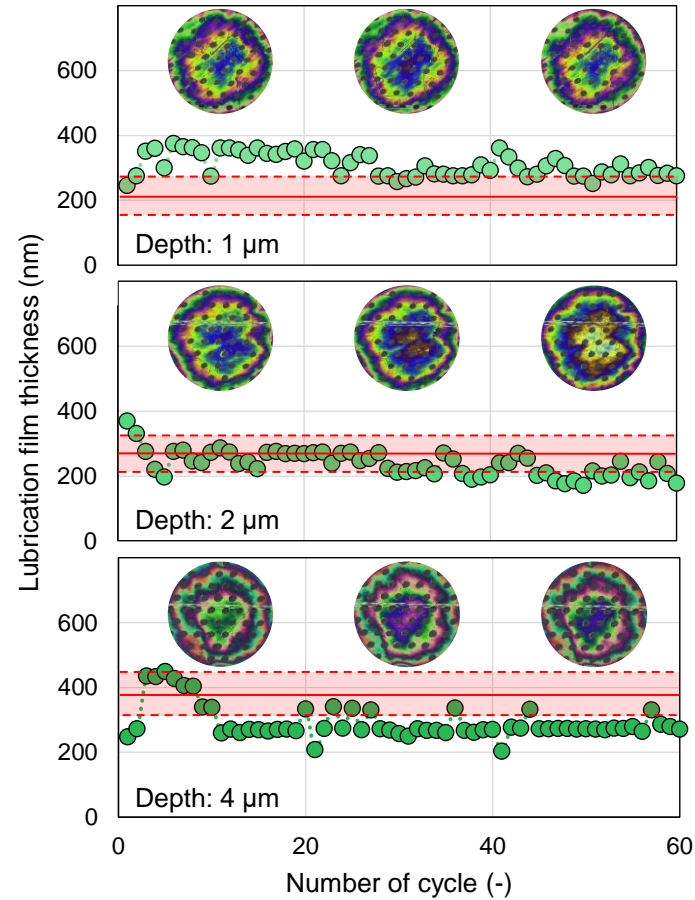

Phase 2

The effect of lasered textures

- Textured surface by laser itself did not improve the overall behaviour due to surface imperfections.
- The electrochemical polishing improved lubrication film in terms of its stability and thickness.
- Coefficient of friction increased for all tested configurations of textures depth.

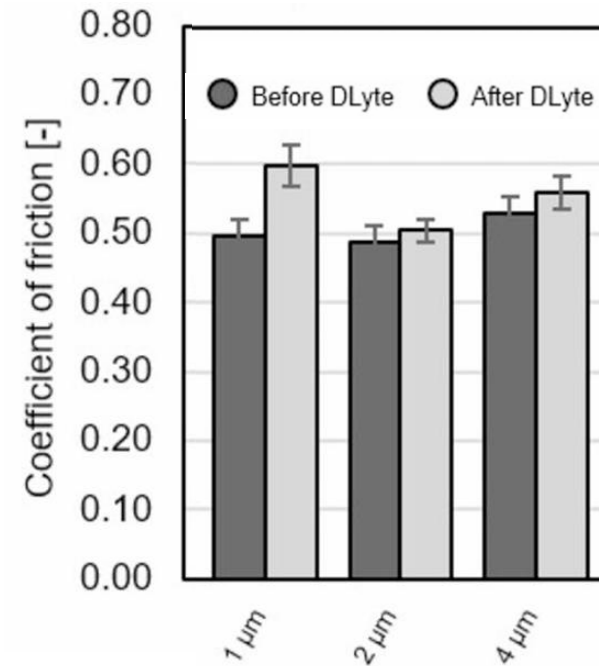

Phase 2

The effect of lasered textures

- Textured surface by laser itself did not improve the overall behaviour due to surface imperfections.
- The electrochemical polishing improved lubrication film in terms of its stability and thickness.
- Coefficient of friction increased for all tested configurations of textures depth.

Well-designed surface texturing and good surface roughness can improve lubricant stability.



Ranuša M, Odehnal L, Kučera O, Nečas D, Hartl M, Křupka I, Vrbka M.
Effect of Surface Texturing on Friction and Lubrication
of Ti6Al4V Biomaterials for Joint Implants.

Tribol Lett 2025;73:15.

Phase 3

The effect of controlled surface structures

Scientific question

How does a controlled surface structure affect the tribological behaviour of AM Ti6Al4V compared with the as-built surface under simulated joint conditions?

Hypothesis

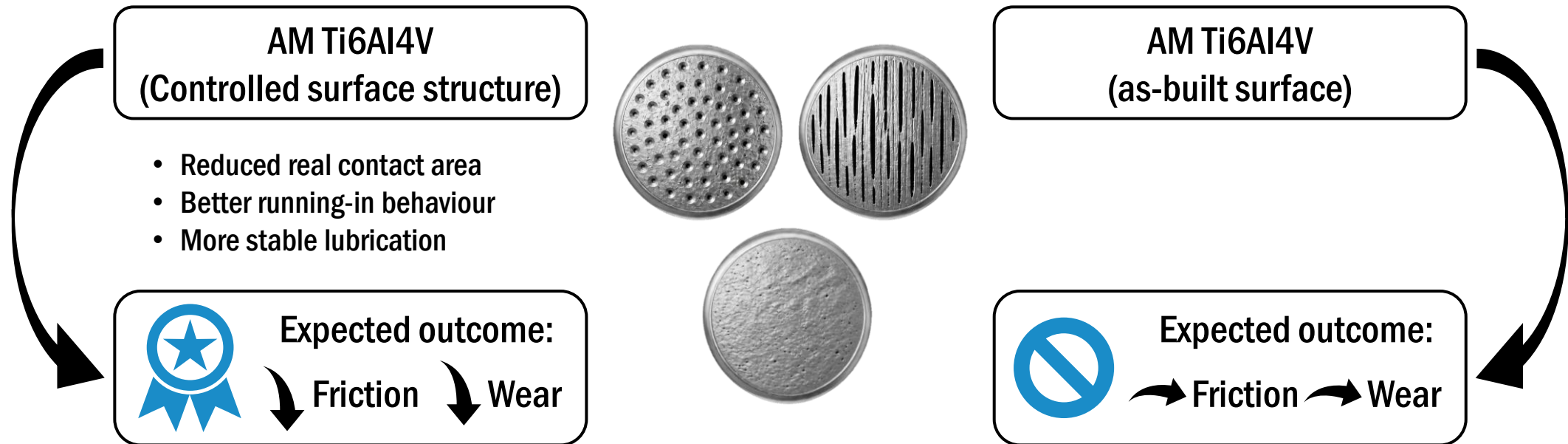

Phase 3

The effect of controlled surface structures

- Visible drop of CoF after unloading phase.
- Stabilisation of CoF for homogeneous and grid samples at lower values compared to line structure.
- Restoration of lubrication thickness after unloading phase visible only for grid structure.
- Grid structure accompanied by the highest amount of albumin in the contact area with visible increase after unloading phase.

Homogenous (as-built)

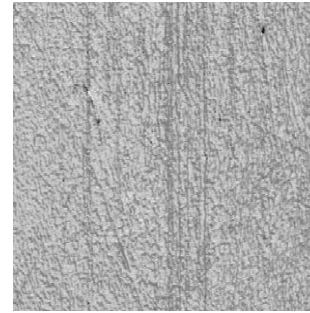

Grid structure

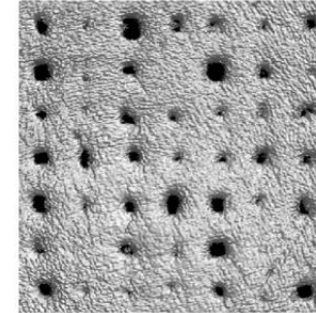

Line structure

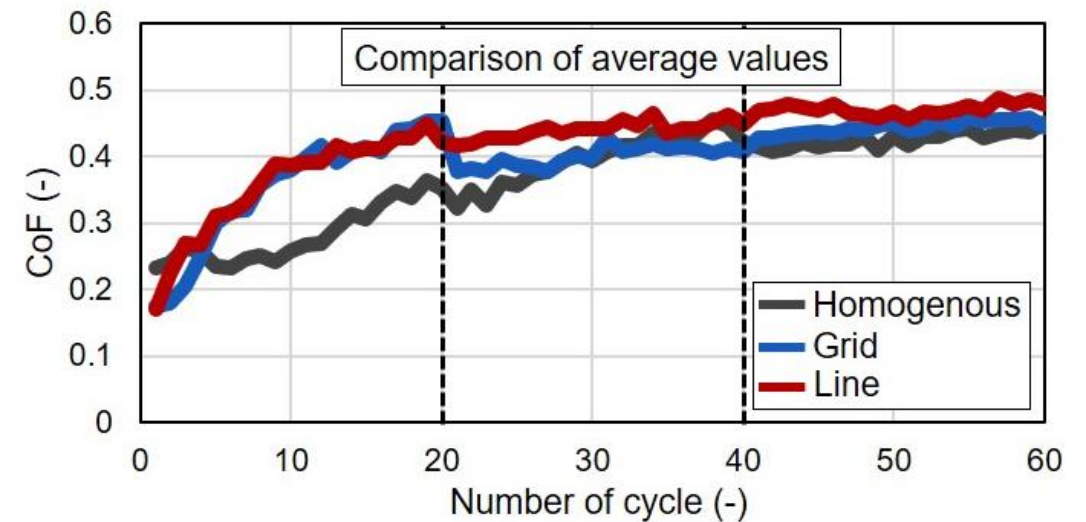
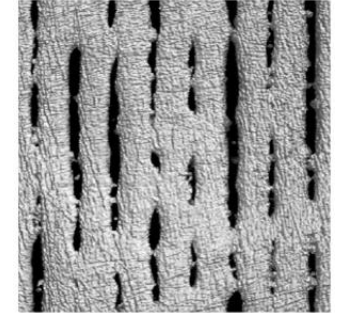

Phase 3

The effect of controlled surface structures

- Visible drop of CoF after unloading phase.
- Stabilisation of CoF for homogeneous and grid samples at lower values compared to line structure.
- Restoration of lubrication thickness after unloading phase visible only for grid structure.
- Grid structure accompanied by the highest amount of albumin in the contact area with visible increase after unloading phase.

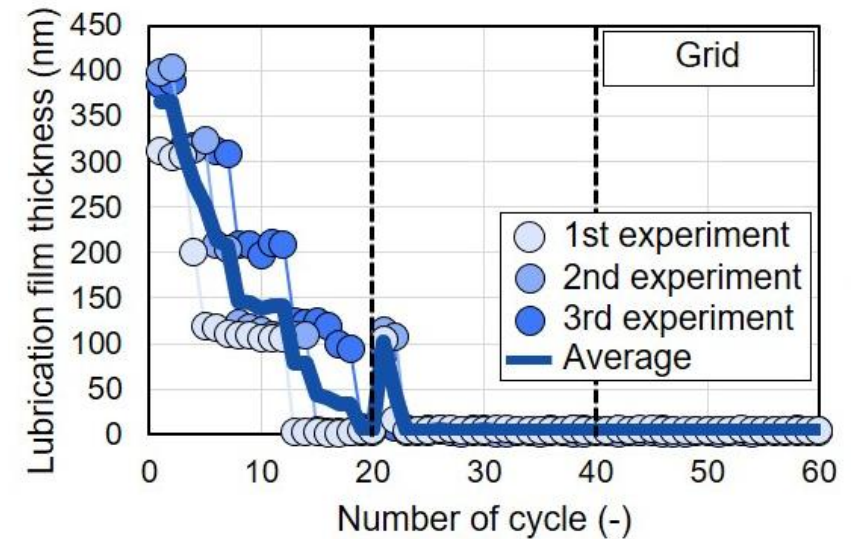
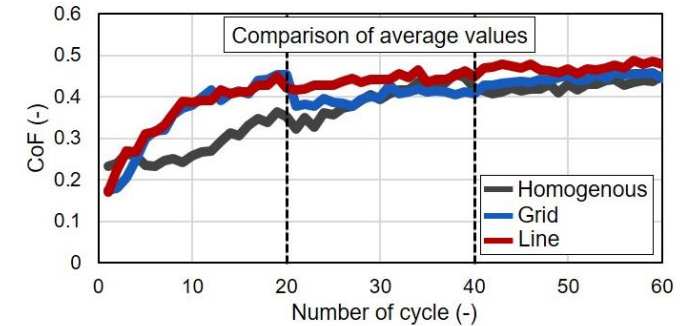

Phase 3

The effect of controlled surface structures

- Visible drop of CoF after unloading phase.
- Stabilisation of CoF for homogeneous and grid samples at lower values compared to line structure.
- Restoration of lubrication thickness after unloading phase visible only for grid structure.
- Grid structure accompanied by the highest amount of albumin in the contact area with visible increase after unloading phase.

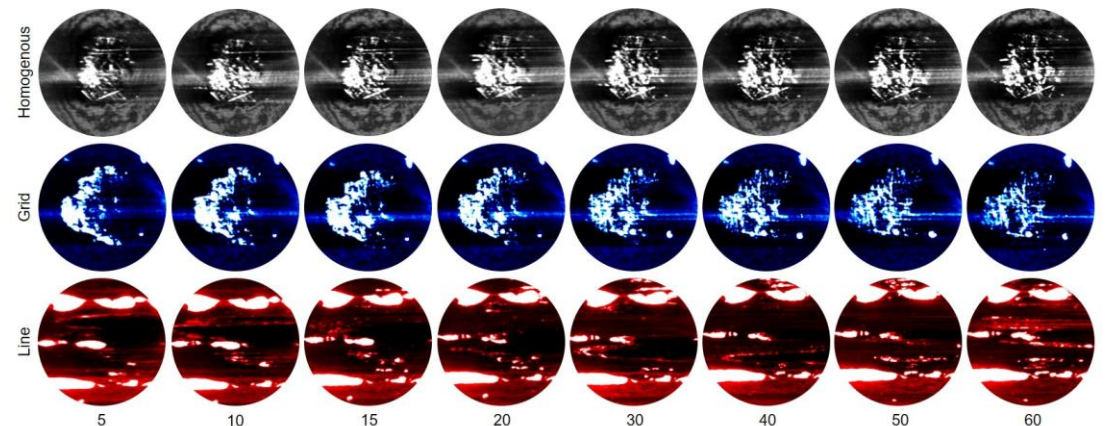
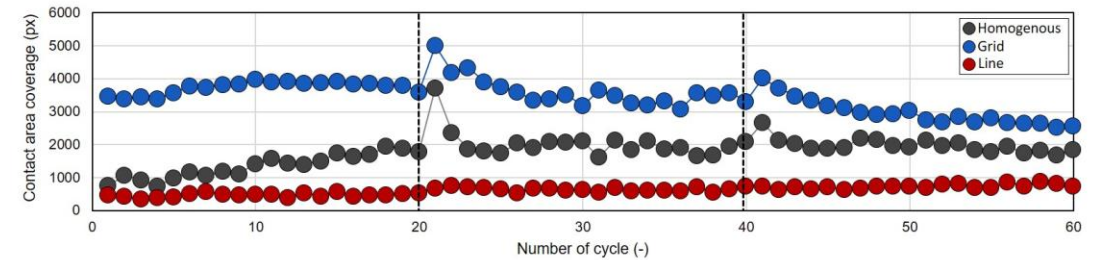
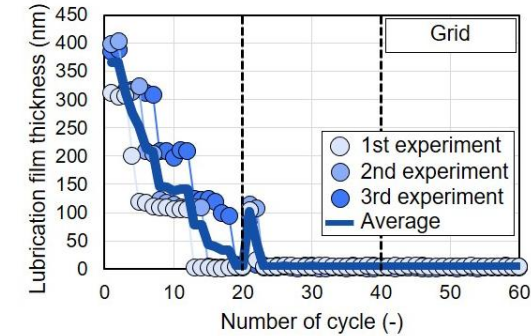

Phase 3

The effect of controlled surface structures

- Visible drop of CoF after unloading phase.
- Stabilisation of CoF for homogeneous and grid samples at lower values compared to line structure.
- Restoration of lubrication thickness after unloading phase visible only for grid structure.
- Grid structure accompanied by the highest amount of albumin in the contact area with visible increase after unloading phase.

The hypothesis was
verified (grid structure)
falsified (line structure)

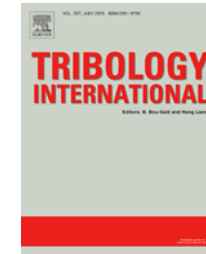

Odehnal L, Ranuša M, Malý M, Křupka I, Koutný D, Hartl M, Vrbka M.
Tribological behaviour of additively manufactured Ti6Al4V
with controlled surface structure: An application in small joint implants.

Tribol Int 2025;211:110832.

Phase 4 Long-term wear performance

Scientific question

How does additively manufactured Ti6Al4V with a targeted grid surface structure affect the long-term wear performance compared to the conventional CoCr30Mo6?

Hypothesis

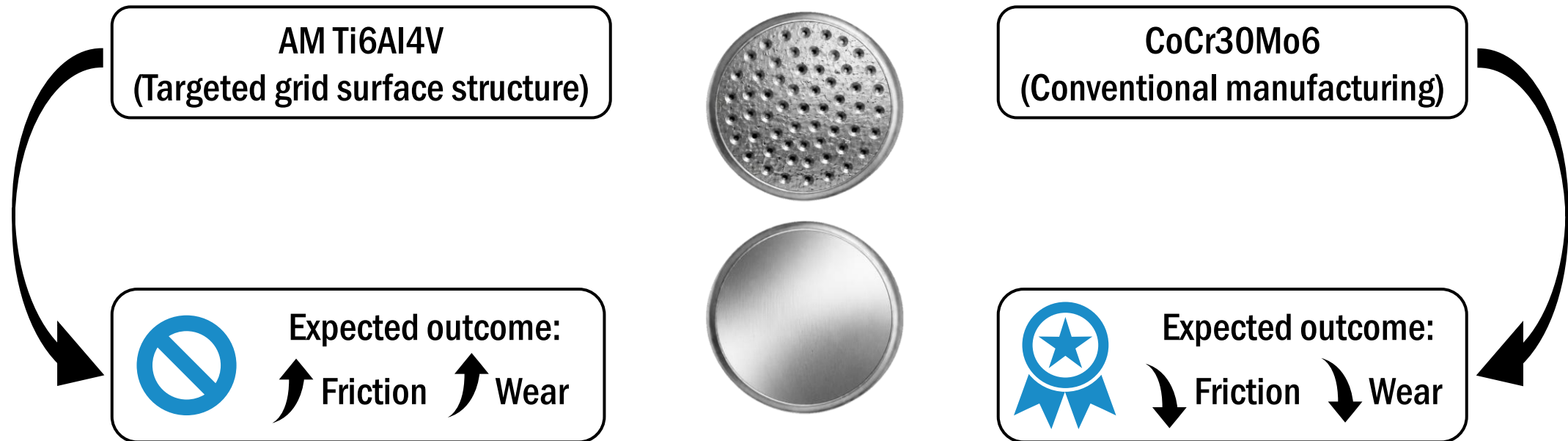

Phase 4

Long-term wear performance

- UHMWPE showed lower total volumetric loss when paired with Ti6Al4V compared to CM CoCr30Mo6.
- UHMWPE plates had several grooves with Ti6Al4V.
- Ti6Al4V pins showed significantly less wear.
- Structures served as effective lubricant reservoirs, thereby improving film stability and providing a longer supply of M-SF constituents.

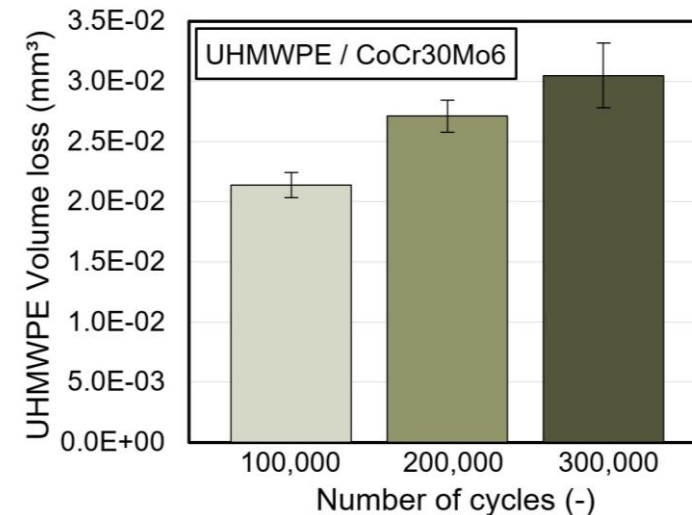
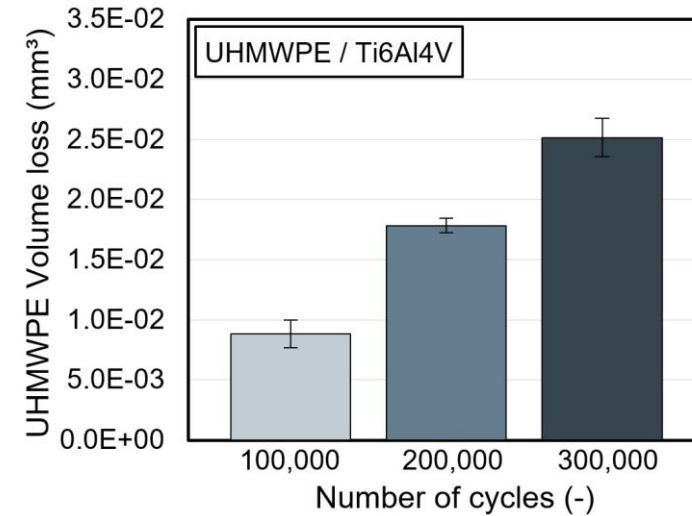

Phase 4 Long-term wear performance

- UHMWPE showed lower total volumetric loss when paired with Ti6Al4V compared to CM CoCr30Mo6.
- UHMWPE plates had several grooves with Ti6Al4V.
- Ti6Al4V pins showed significantly less wear.
- Structures served as effective lubricant reservoirs, thereby improving film stability and providing a longer supply of M-SF constituents.

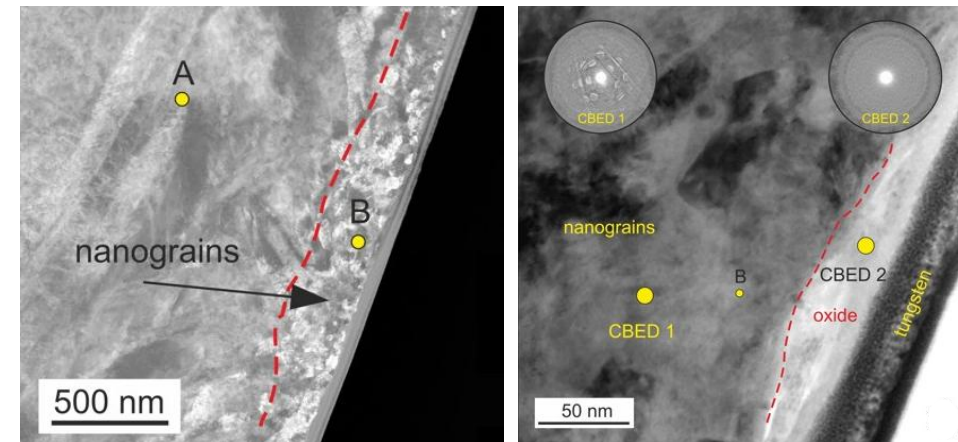
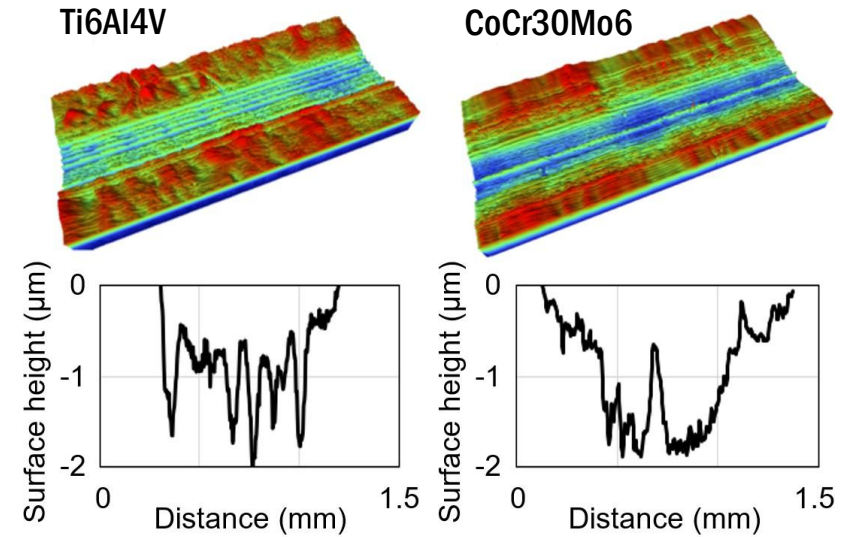

Phase 4

Long-term wear performance

- UHMWPE showed lower total volumetric loss when paired with Ti6Al4V compared to CM CoCr30Mo6.
- UHMWPE plates had several grooves with Ti6Al4V.
- Ti6Al4V pins showed significantly less wear.
- Structures served as effective lubricant reservoirs, thereby improving film stability and providing a longer supply of M-SF constituents.

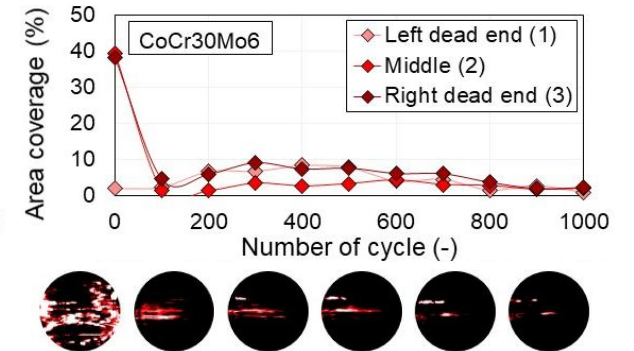
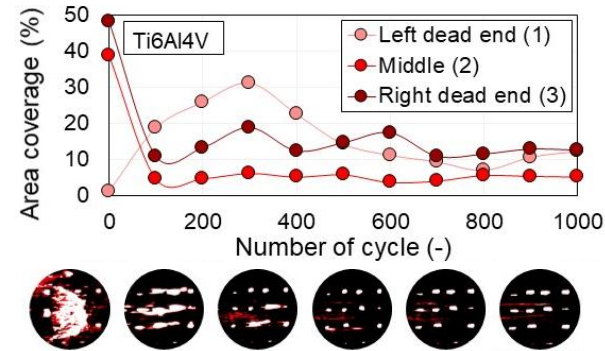

Phase 4

Long-term wear performance

- UHMWPE showed lower total volumetric loss when paired with Ti6Al4V compared to CM CoCr30Mo6.
- UHMWPE plates had several grooves with Ti6Al4V.
- Ti6Al4V pins showed significantly less wear.
- Structures served as effective lubricant reservoirs, thereby improving film stability and providing a longer supply of M-SF constituents.

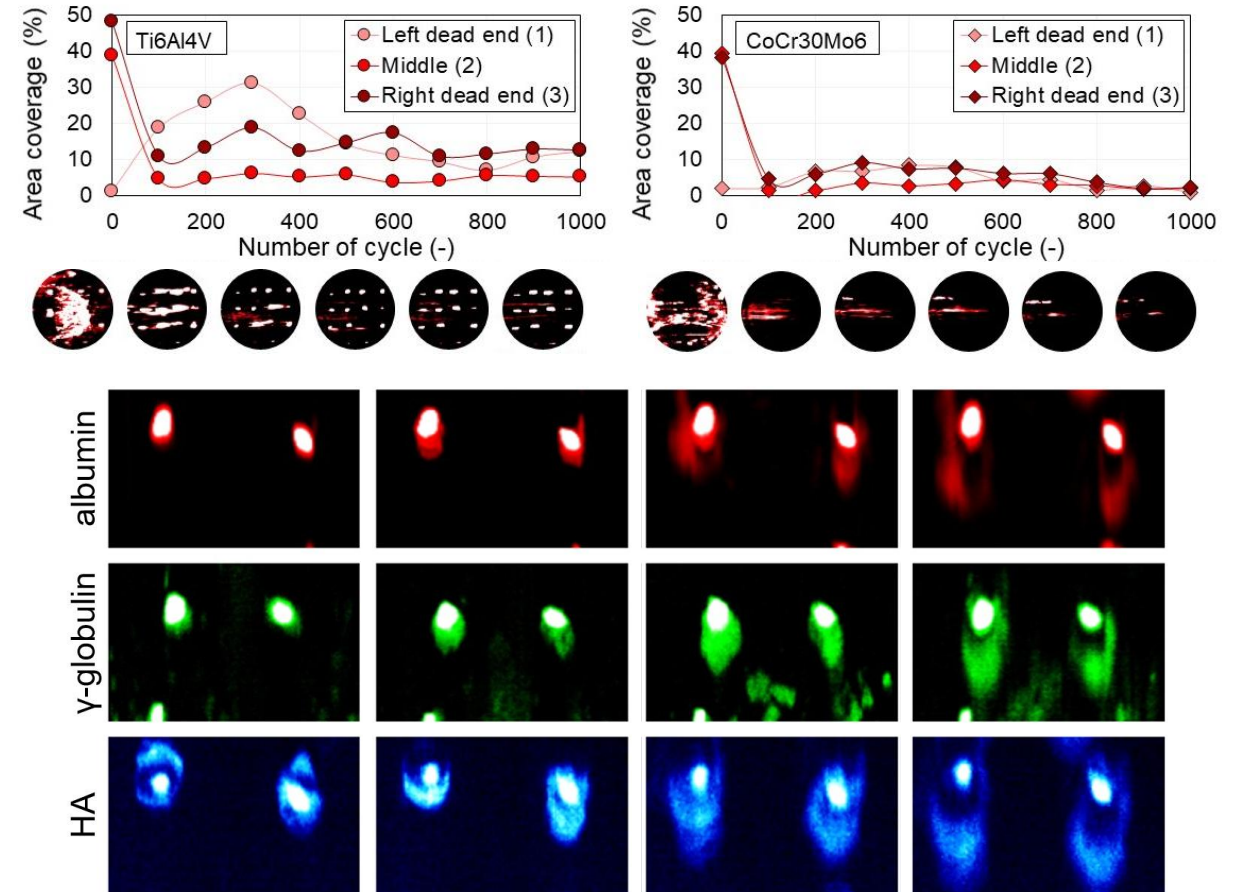

Phase 4

Long-term wear performance

- UHMWPE showed lower total volumetric loss when paired with Ti6Al4V compared to CM CoCr30Mo6.
- UHMWPE plates had several grooves with Ti6Al4V.
- Ti6Al4V pins showed significantly less wear.
- Structures served as effective lubricant reservoirs, thereby improving film stability and providing a longer supply of M-SF constituents.

**The hypothesis was
falsified.**

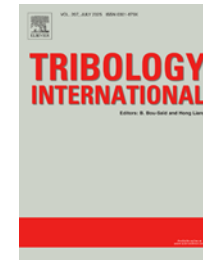

Odehnal L, Ranuša M, Čípek P, Malý M, Mazánová V, Dlouhý A, Koutný D, Hartl M, Vrbka M.
Additively manufactured Ti6Al4V with controlled surface structure as a Potential Material
for Joint Implant: Long-Term Wear Performance and Durability.

Tribol Int 2025;216:111599.

Summary of Main Outcomes

- **Conventionally manufactured Ti6Al4V without any surface modifications is not suitable for frictional pairs.**
- Surface laser texturing showed promising results, as some configurations overcome the surface roughness and created sufficiently thick lubrication film to separate frictional pair.
- Grid structure showed promising results in terms of short experiments.
- Grid structure created directly during the 3D printing process overcome the behaviour of CM CoCr30Mo6.

CM Ti6Al4V



Laser textures



3D printing



Long-term

Summary of Main Outcomes

- Conventionally manufactured Ti6Al4V without any surface modifications is not suitable for frictional pairs.
- Surface laser texturing showed promising results, as some configurations overcome the surface roughness and created sufficiently thick lubrication film to separate frictional pair.
- Grid structure showed promising results in terms of short experiments.
- Grid structure created directly during the 3D printing process overcome the behaviour of CM CoCr30Mo6.

CM Ti6Al4V

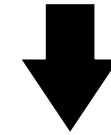

Laser textures



3D printing



Long-term

Summary of Main Outcomes

- Conventionally manufactured Ti6Al4V without any surface modifications is not suitable for frictional pairs.
- Surface laser texturing showed promising results, as some configurations overcome the surface roughness and created sufficiently thick lubrication film to separate frictional pair.
- Grid structure showed promising results in terms of short experiments.
- Grid structure created directly during the 3D printing process overcome the behaviour of CM CoCr30Mo6.

CM Ti6Al4V

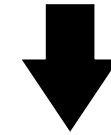

Laser textures

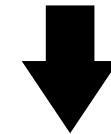

3D printing



Long-term

Summary of Main Outcomes

- Conventionally manufactured Ti6Al4V without any surface modifications is not suitable for frictional pairs.
- Surface laser texturing showed promising results, as some configurations overcome the surface roughness and created sufficiently thick lubrication film to separate frictional pair.
- Grid structure showed promising results in terms of short experiments.
- Grid structure created directly during the 3D printing process overcome the behaviour of CM CoCr30Mo6.

CM Ti6Al4V

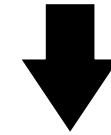

Laser textures

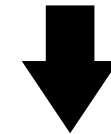

3D printing

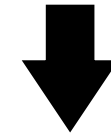

Long-term

Medical Applicability and Future Work

- The results are mainly relevant for preclinical optimisation of joint implants.
- AM Ti6Al4V shows potential for the development of next-generation joint implants.
- Further investigate how AM process parameters influence surface morphology, subsurface microstructure, and long-term tribological behaviour of Ti6Al4V.
- Application of gained knowledge on ongoing research projects.



3D printed individualised segmental joint implant:
optimisation of fixation to bone and biotribology
of articular surface (NW25-08-00044)

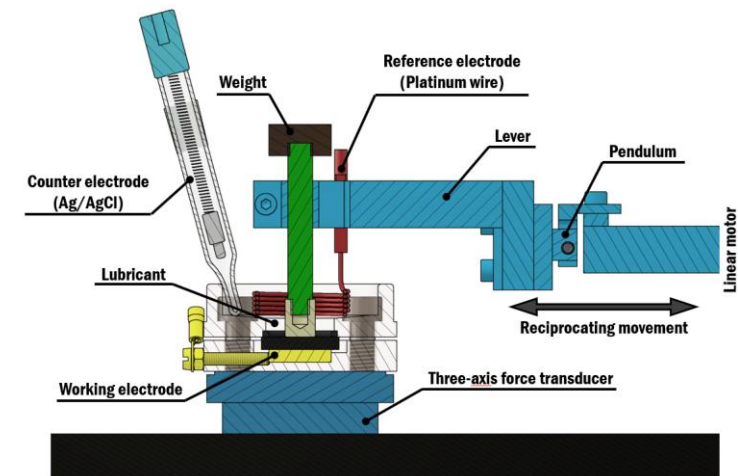
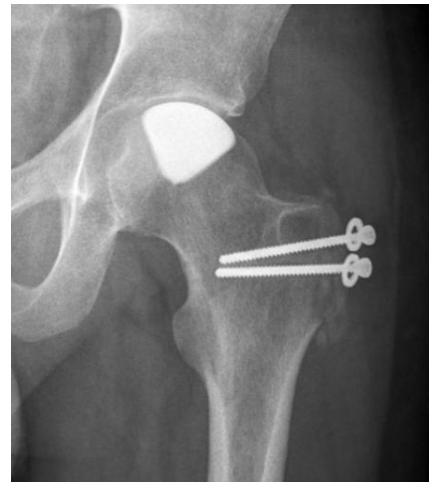

Overview of Doctoral Research Outputs

Published Articles

Odehnal L, Ranuša M, Vrbka M, Křupka I, Hartl M. Tribological Behaviour of Ti6Al4V Alloy: An Application in Small Joint Implants. Tribol Lett 2023;71:125.

Ranuša M, **Odehnal L**, Kučera O, Nečas D, Hartl M, Křupka I, Vrbka M. Effect of Surface Texturing on Friction and Lubrication of Ti6Al4V Biomaterials for Joint Implants. Tribol Lett 2025;73:15.

Odehnal L, Ranuša M, Malý M, Křupka I, Koutný D, Hartl M, Vrbka M. Tribological behaviour of additively manufactured Ti6Al4V with controlled surface structure: An application in small joint implants. Tribol Int 2025;211:110832.

Odehnal L, Ranuša M, Čípek P, Malý M, Dlouhý A, Mazánová V, Koutný D, Hartl M, Vrbka M. Additively manufactured Ti6Al4V with controlled surface structure as a Potential Material for Joint Implants: Long-Term Wear Performance and Durability. Tribol Int 2026;216:111599.

Odehnal L, Ranuša M, Wimmer MA, Vrbka M, Křupka I. Development of lubrication film and influence on friction in a total knee replacement during a gait cycle. Tribol Int 2023;178:108073.

Rebenda D, **Odehnal L**, Uhrová S, Nečas D, Vrbka M. On the Friction and Lubrication of 3D Printed Ti6Al4V Hip Joint Replacement. Tribol Lett 2025;73:68.

Functional Prototypes

Čípek P, Ranuša M, **Odehnal L**, Vrbka M. Simulator for Examination of Wear in Small Joint Implants.

Conference Contributions

Odehnal L, Ranuša M, Malý M, Vrbka M, Hartl M. Additive Manufacturing as a Potential Method to Produce Friction Surfaces of Joint Implants: The Tribological Behaviour of Ti6Al4V. ECOTRIB23, 2023, Bari, Italy.

Odehnal L, Ranuša M, Malý M, Vrbka M. Additively Manufactured Ti6Al4V with Controlled Surface Structure as a Potential Material for Small Joint Implants. ICTMP2024, 2024, Alcoy, Spain.

Odehnal L, Ranuša M, Malý M, Vrbka M, Hartl M. Additive Manufacturing as a Potential Method to Produce Friction Surfaces of Joint Implants: The Tribological Behaviour of Ti6Al4V. 49th Leeds-Lyon Symposium on Tribology, 2024, Lyon, France.

Odehnal L, Ranuša M, Vrbka M, Křupka I, Hartl M. AM Ti6Al4V with Controlled Surface Structure: Long-Term Wear Performance and Durability. ECOTRIB25, 2025, Zurich, Switzerland.

Odehnal L, Ranuša M, Malý M, Vrbka M, Hartl M. Tribocorrosion Study of AM Ti6Al4V with Surface Structure and UHMWPE Interfaces Under Synovial Fluid Degradation: Insights from a Scientific Mobility at EPFL. Conference MEBioSys 2025, Brno, Czech Republic.

Scientific Mobilities

École Polytechnique fédérale de Lausanne (EPFL), Switzerland, June – August 2025. Tribocorrosion Study of AM Ti6Al4V with Surface Structure and UHMWPE Interfaces Under Synovial Fluid Degradation.

THANK YOU FOR YOUR ATTENTION!

Lukáš Odehnal

Lukas.Odehnal@vut.cz

The research was supported by the projects:



„Friction and lubrication of small joint implants produced by 3D metal printing additive technology”,
funded as project No. 22-02154S by Czech Science Foundation.



"Mechanical Engineering of Biological and Bio-inspired Systems",
funded as project No. CZ.02.01.01/00/22_008/0004634 by Programme Johannes Amos Comenius, call Excellent Research.



„3D printed individualised segmental joint implant: optimisation of fixation to bone and biotribology of articular surface”,
funded as project No. NW25-08-00044 by the Ministry of Health of the Czech Republic in cooperation with the Czech Health Research Council.